

EMC Test Report

Applicant's Name.....: Dongguan Zhiyihong hardware and Plastics Co., Ltd.
Address.....: Room 101, building 1, No.110, Humen Xinfeng Road, Humen TownDongguan City, Guangdong Province
Manufacturer's Name.....: Dongguan Zhiyihong hardware and Plastics Co., Ltd.
Address.....: Room 101, building 1, No.110, Humen Xinfeng Road, Humen TownDongguan City, Guangdong Province

Product Description:

Product Name.....: Pet Water Dispenser
WF190, WF040, WF050, WF020, WF020TP, WF020WH, WF050TP, WF060, WF070, WF080, WF090, WF100, WF110, WF120, WF130, WF140, WF150, WF160, WF170, WF180, WF200, WF210, WF220, WF230, WF030, WF240, WF250, WF260, WF270, WF280, WF290, WF300, WF310, WF320, WF330, WF340, WF350, WF360, WF370, WF380, WF390, WF400, WF410, WF420, WF430, WF440, WF450, WF460, WF470, WF480, WF490, WF500, WF510, WF520, WF530, WF540, WF550, WF560, WF570, WF580, WF590, WF600, WF610, WF620, WF630, WF640, WF650, WF660, WF670, WF680, WF690, WF700, WF710, WF720, WF730, WF740, WF750, WF760, WF770, WF780, WF790, WF800

Model Name.....: EN IEC 55014-1:2021
EN IEC 61000-3-2:2019+A1
EN 61000-3-3:2013+A1:2019
EN IEC 55014-2:2021

Standards.....: EN IEC 61000-3-2:2019+A1
EN 61000-3-3:2013+A1:2019
EN IEC 55014-2:2021

Report Version.....: B01

This device described above has been tested by Promise, and the test results show that the equipment under test (EUT) is in compliance with the EMC Directive **SI 2016 No.1091/UK** requirements. And it is applicable only to the tested sample identified in the report.

This report shall not be reproduced except in full, without the written approval of Promise, this document may be altered or revised by Promise, personal only, and shall be noted in the revision of the document.

Date of Test:

Date (s) of Performance of Tests.....: Nov. 20, 2024 ~ Nov. 22, 2024
Date of Issue.....: Jun. 12, 2025
Test Result.....: **Pass**

Prepared By : Yann
(Yann)

Reviewed by : Chopin. Xiao
(Chopin Xiao)

Approved by : Kind. yang
(Kind yang)

Report Revise Record

Report Version	Revise Time	Issued Date	Valid Version	Notes
V1.0	/	Jun. 12, 2025	Valid	Original Report



TABLE OF CONTENTS

1.TEST SUMMARY	4
2. GENERAL INFORMATION	5
2.1 GENERAL DESCRIPTION OF THE EUT	5
2.2 DESCRIPTION OF THE TEST MODES	6
2.3 TEST CONFIGURATION DIAGRAM	6
2.4 DESCRIPTION TEST PERIPHERAL AND EUT PERIPHERAL	7
2.5 TEST LOCATION	8
2.6 MEASUREMENT UNCERTAINTY	8
2.7 MEASUREMENT INSTRUMENTS LIST	9
3. EMC EMISSION TEST	11
3.1 CONDUCTED EMISSION MEASUREMENT	11
3.2 RADIATED EMISSION MEASUREMENT	15
3.3 HARMONICS CURRENT	19
3.4 VOLTAGE FLUCTUATION AND FLICKERS	21
4.EMC IMMUNITY TEST	21
4.1 STANDARD COMPLIANCE/SERVURITY LEVEL/CRITERIA	22
4.2 GENERAL PERFORMANCE CRITERIA	23
4.3 ELECTROSTATIC DISCHARGE IMMUNITY TEST (ESD)	24
4.4 RADIATED, RADIO-FREQUENCY, ELECTROMAGNETIC FIELD IMMUNITY TEST(RS)	28
4.5 ELECTRICAL FAST TRANSIENT (EFT)	31
4.6 SURGE TESTING	35
4.7 CONDUCTED RADIO FREQUENCY DISTURBANCES (CS)	38
4.8 VOLTAGE INTERRUPTION/DIPS TESTING (DIPS)	41
APPENDIX 1-TEST SETUP	43
APPENDIX 2-PHOTOGRAPHS OF EUT CONSTRUCTIONAL DETAILS	46

1. TEST SUMMARY

Test procedures according to the technical standards:

EMC Emission				
Standard	Test Item	Limit	Judgment	Remark
BS EN IEC 55014-1:2021	Conducted Emission on AC And Telecom Port 150kHz to 30MHz	---	PASS	
	Disturbance Power(30-300MHz)	Meets the requirements	N/A	
	Radiated Emission 30MHz to 1000MHz	---	PASS	NOTE (1)
BS EN IEC 61000-3-2:2019+A1	Harmonic Current Emission	A	N/A	
EN 61000-3-3:2013+A1:2019	Voltage Fluctuations & Flicker	---	PASS	
EMC Immunity				
Section BS EN IEC 55014-2:2021	Test Item	Performance Criteria	Judgment	Remark
EN 61000-4-2:2009	Electrostatic discharges	B	PASS	
EN 61000-4-3:2006+A1:2008+A2:2010	RF Electromagnetic Field	A	PASS	
EN 61000-4-4:2012	Electrical fast transients/burst	B	PASS	
EN 61000-4-5:2014+A1:2017	Surges	B	PASS	
EN 61000-4-6:2014+AC:2015	Continuous induced RF disturbances	A	PASS	
EN 61000-4-11:2004+A1:2017	Voltage dips and interruptions	C / C / C	PASS	NOTE (2)

Note:

- (1) Radiated Emission 30MHz to 1000MHz only apply when test fail in Disturbance Power(200-300MHz) or the maximum clock frequency more than 30MHz.
- (2) Voltage Dip: 100% reduction – Performance Criteria **C**
Voltage Dip: 30% reduction – Performance Criteria **C**
Voltage Dip: 60% reduction – Performance Criteria **C**
- (3) "N/A" denotes test is not applicable in this Test Report

2. GENERAL INFORMATION

2.1 GENERAL DESCRIPTION OF THE EUT

Product Name	Pet Water Dispenser
Trade Mark	N/A
Model Name	WF190, WF040, WF050, WF020, WF020TP, WF020WH, WF050TP, WF060, WF070, WF080, WF090, WF100, WF110, WF120, WF130, WF140, WF150, WF150, WF160, WF170, WF180, WF200, WF210, WF220, WF230, WF030, WF240, WF250, WF260, WF270, WF280, WF290, WF300, WF310, WF320, WF330, WF340, WF350, WF360, WF370, WF380, WF390, WF400, WF410, WF420, WF430, WF440, WF450, WF460, WF470, WF480, WF490, WF500, WF510, WF520, WF530, WF540, WF550, WF560, WF570, WF580, WF590, WF600, WF610, WF620, WF630, WF640, WF650, WF660, WF670, WF680, WF690, WF700, WF710, WF720, WF730, WF740, WF750, WF760, WF770, WF780, WF790, WF800
Model Distiction	Model name is different
Sampling model	WF190
Test Sample Number	PRMS075241146A01
Product Description	The EUT is a Pet Water Dispenser More details of EUT technical specification, please refer to the User's Manual.
Power Rating	AC 100-240V,50Hz,0.5A
EUT Highest internal frequency:	<input checked="" type="checkbox"/> $F_x \leq 108\text{MHz}$ <input type="checkbox"/> $108 < F_x \leq 500\text{MHz}$ <input type="checkbox"/> $500\text{MHz} < F_x \leq 1\text{GHz}$ <input type="checkbox"/> $F_x > 1\text{GHz}$
Hardware Version Number	N/A
Software Version Number	N/A

2.2 DESCRIPTION OF THE TEST MODES

characteristics generation from EUT, the test system was pre scanned and was tested on the basis of the consideration of the following EUT operation mode or test configuration mode which possibly have an effect on EMI emission level.

Pretest Mode	Description
Mode 1	Working

For Conducted Test	
Final Test Mode	Description
Mode 1	Working

For Radiated Test	
Final Test Mode	Description
Mode 1	Working

For EMS Test	
Final Test Mode	Description
Mode 1	Working

Note:

1. For conducted emission test, test mode 1 was the worst case and only this mode was presented in this report.
2. For radiated emission test, test mode 1 was the worst case and only this mode was presented in this report.

2.3 TEST CONFIGURATION DIAGRAM

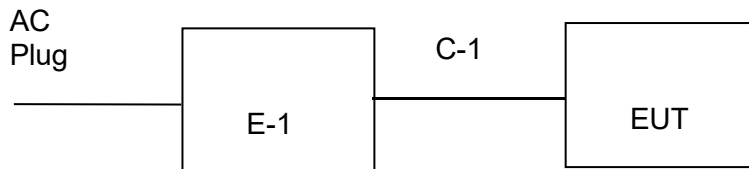

2.4 DESCRIPTION TEST PERIPHERAL AND EUT PERIPHERAL

The EUT has been tested as an independent unit together with other necessary accessories or support units. The following support units or accessories were used to form a representative test configuration during the tests.

Accessories equipment

Item	Equipment	Mfr/Brand	Model/Type No.
E-1	Adapter	N/A	N/A
C-1	DC Line	N/A	N/A

Auxiliary equipment

Item	Equipment	Mfr/Brand	Model/Type No.
N/A	N/A	N/A	N/A

Cable

Item	Type	Shielded Type	Ferrite Core	Length
N/A	N/A	N/A	N/A	N/A

Note:

- (1) The support equipment was authorized by Declaration of Confirmation.
- (2) For detachable type I/O cable should be specified the length in cm in 『Length』 column.
- (3) “YES” means “shielded” “with core”; “NO” means “unshielded” “without core”.

2.5 TEST LOCATION

Site	Shenzhen Promise Test Technology Co., Ltd.
Location	103, Building 1, Yibaolai Industrial City, Qiaotou Community, Fuhai Street, Bao'an District, Shenzhen, Guangdong, China
Telephone:	0755-23319501

2.6 MEASUREMENT UNCERTAINTY

The reported uncertainty of measurement $y \pm U$, where expanded uncertainty U is based on a standard uncertainty multiplied by a coverage factor of $k=2$, providing a level of confidence of approximately 95 %.

A. Conducted Measurement:

Test Site	Method	Measurement Frequency Range	U · (dB)	NOTE
Conducted Emission	CISPR 16-4-2	150KHz ~ 30MHz	2.90	

B. Radiated Measurement:

Test Site	Method	Measurement Frequency Range	U · (dB)	NOTE
Radiated Emission	CISPR 16-4-2	30MHz ~ 1000MHz	5.19	

2.7 MEASUREMENT INSTRUMENTS LIST

Conducted Emission Test					
Equipment	Manufacturer	Model#	Serial#	Last Cal.	Next Cal
843 Shielded Room	ChengYu	843 Room	843	May. 13, 2025	May. 12, 2029
EMI Receiver	R&S	ESCI3	100306	May. 14, 2025	May. 13, 2026
LISN	ETS-LINDGREN	3810/2	00045732	May. 14, 2025	May. 10, 2025
Attenuator	SUHNER	ESH3-Z2	100243	May. 14, 2025	May. 10, 2025
843 Cable 1#	FUJIKURA	843C1#	001	May. 14, 2025	May. 10, 2025
Test software	FALA	EZ-EMC	EMC-CON3A1.1		--

Radiation Emission Test					
Equipment	Manufacturer	Model#	Serial#	Last Cal.	Next Cal.
966 chamber	ChengYu	966 Room	966	May. 23, 2025	May. 12, 2029
Spectrum Analyzer	Agilent	N9020A	MY54440442	May. 14, 2025	May. 13, 2026
Low-Noise Amplifier	HEWLETT PACKARD	8447D	2727A05439	May. 14, 2025	May. 13, 2026
Log-periodic Antenna	SunAR	JB6	A121411	May. 14, 2025	May. 13, 2026
EMI Receiver	R&S	ESCI3	100306	May. 14, 2025	May. 13, 2026
966 Cable 1#	CHENGYU	966	003	May. 14, 2025	May. 13, 2026
Test software	FALA	EZ-EMC	FA-03A2 RE+		--

Harmonic/Flicker Test					
Equipment	Manufacturer	Model#	Serial#	Last Cal.	Next Cal.
Harmonic & Voltage Flicker	LAPLACE	AC 2000A	--	May. 14, 2025	May. 13, 2026
AC Power Source	LAPLACE	DAL40	10003021350179	May. 14, 2025	May. 13, 2026
Testing Software	HTEC	V1.5	--	--	--

For Electrostatic Discharge/ Electrical Fast Transients/ Voltage Dips and Interruptions Test					
Equipment	Manufacturer	Model#	Serial#	Last Cal.	Next Cal.
Combined interference generator	Prima	EED2005TG	PR210554993	May. 14, 2025	May. 13, 2026

Capacitive coupling clamp	Prima	EFT-CLAMP	EFT-198	May. 14, 2025	May. 13, 2026
ESD generator	Prima	EED2005TG	PR210554993	May. 14, 2025	May. 13, 2026

For Surges Test					
Equipment	Manufacturer	Model#	Serial#	Last Cal.	Next Cal.
Lightning surge generator	Prima	SUG61005TB	PR210554993	May. 14, 2025	May. 13, 2026

Immunity to conducted disturbances, induced by radio-frequency fields (CS)					
Equipment	Manufacturer	Model#	Serial#	Last Cal.	Next Cal.
Conducted Immunity Test System	Schloder	CDG-7000-75	126B129012014	May. 14, 2025	May. 13, 2026
CDN	Schloder	CNDM2+M3-16	N/A	May. 14, 2025	May. 13, 2026
EM-Clamp	Schloder	EMCL-20	132A1194/2014	May. 14, 2025	May. 13, 2026
RF Attenuator	Schloder	75w 6dB	N/A	May. 14, 2025	May. 13, 2026

Radiated, radio-frequency, electromagnetic field immunity (RS)					
Equipment	Manufacturer	Model#	Serial#	Last Cal.	Next Cal.
Antenna	SKET	STLP 9129_Plus	/	/	/
Signal Generator	Agilent	N5181A	MY50141997	Feb. 01, 2024	Jan. 31, 2025
Amplifier	SKET	HAP_80M01G-250W	202105183	Jun. 27, 2024	Jun. 26, 2025
Amplifier	SKET	HAP_03G06G-80W	202305501	Jun. 27, 2024	Jun. 26, 2025
Field Probe	Narda	EP-601	811ZX01057	Jun. 29, 2024	Jun. 28, 2025
USB Power Sensor	Agilent	U2001A	MY53410013	Feb. 01, 2024	Jan. 31, 2025
USB Power Sensor	Agilent	U2001A	MZ54330012	Feb. 01, 2024	Jan. 31, 2025

3. EMC EMISSION TEST

3.1 CONDUCTED EMISSION MEASUREMENT

3.1.1 POWER LINE CONDUCTED EMISSION

(Frequency Range 150KHz-30MHz)

FREQUENCY (MHz)	At load terminals and additional terminals(dBuV)		At mains terminals(dBuV)	
	Quasi-peak	Average	Quasi-peak	Average
0.15 -0.5	80.00	70.00	66 - 56 *	59 - 46 *
0.50 -5.0	74.00	64.00	56.00	46.00
5.0 -30.0	74.00	64.00	60.00	50.00

Note:

- (1) The tighter limit applies at the band edges.
- (2) The limit of " * " marked band means the limitation decreases linearly with the logarithm of the frequency in the range.

The following table is the setting of the receiver

Receiver Parameters	Setting
Attenuation	10 dB
Start Frequency	0.15 MHz
Stop Frequency	30 MHz
IF Bandwidth	9 kHz

3.1.2 TEST PROCEDURE

- a. The EUT was placed 0.4 meters from the conducting wall of the shielded room with EUT being connected to the power mains through a line impedance stabilization network (LISN). Other support units were connected to the power mains through another LISN. The two LISNs provide 50 Ohm/ 50uH of coupling impedance for the measuring instrument.
- b. Interconnecting cables that hang closer than 40 cm to the ground plane shall be folded back and forth in the center forming a bundle 30 to 40 cm long.
- c. I/O cables that are not connected to a peripheral shall be bundled in the center. The end of the cable may be terminated, if required, using the correct terminating impedance. The overall length shall not exceed 1 m.
- d. For the actual test configuration, please refer to the related Item –EUT Test Photos.

3.1.3 TEST SETUP

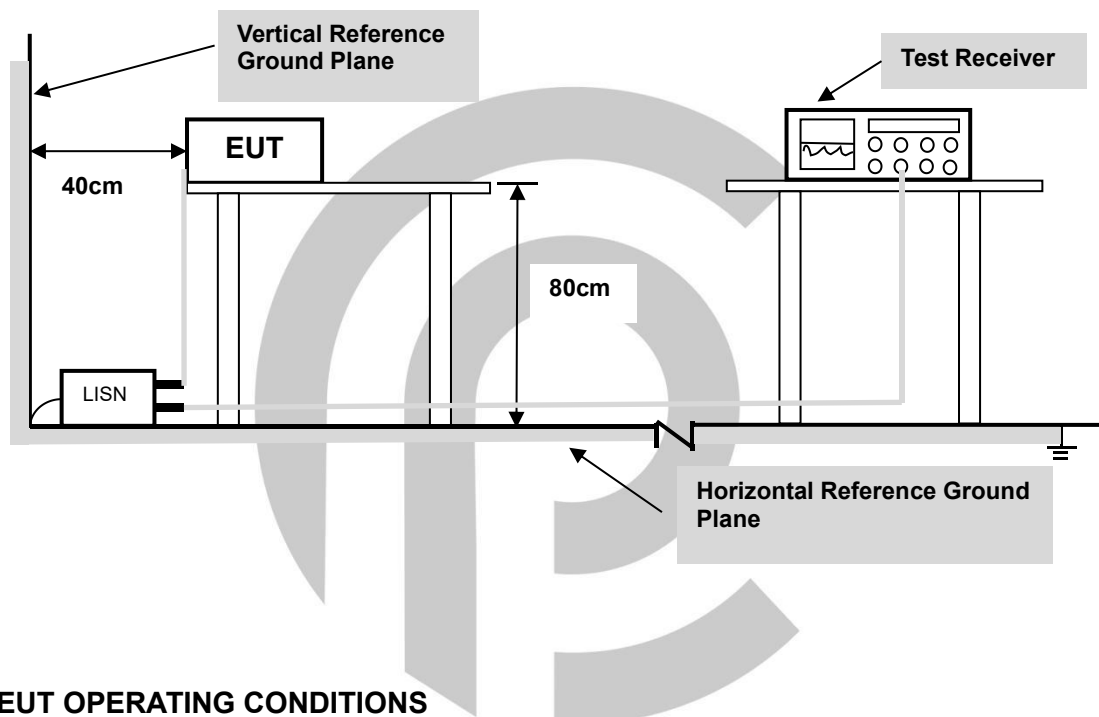

3.1.4 EUT OPERATING CONDITIONS

The EUT tested system was configured as the statements of 2.3 Unless otherwise a special operating condition is specified in the following during the testing.

3.1.5 TEST RESULTS

Temperature:	21 °C	Relative Humidity:	43%
Phase:	L	Test Mode:	Mode 1
Test Voltage:	AC 230V/50Hz	Test Date:	2023.01.18

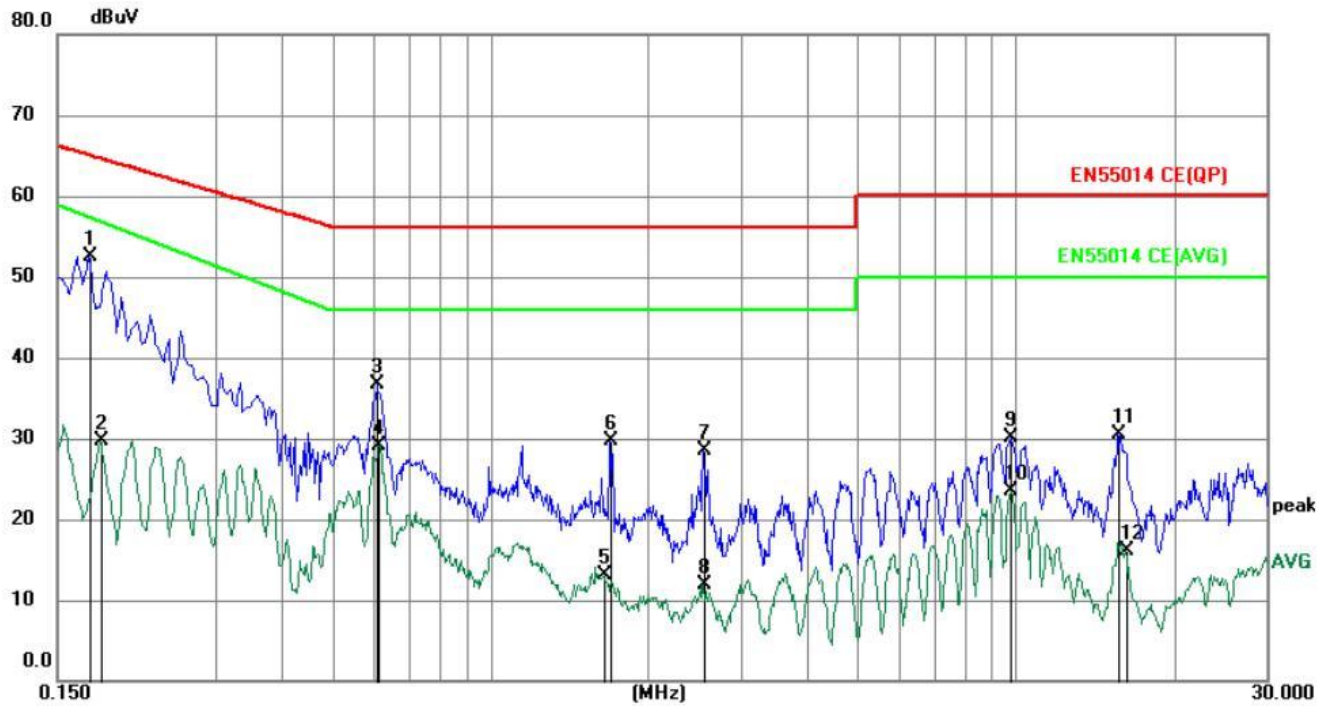

No.	Frequency (MHz)	Reading (dBuV)	Factor (dB)	Level (dBuV)	Limit (dBuV)	Margin (dB)	Detector	P/F	Remark
1	0.1725	40.07	12.51	52.58	64.84	-12.26	peak	P	
2	0.1815	17.28	12.33	29.61	56.94	-27.33	AVG	P	
3	0.6090	26.16	10.52	36.68	56.00	-19.32	peak	P	
4	0.6134	18.66	10.52	29.18	46.00	-16.82	AVG	P	
5	1.6485	2.79	10.28	13.07	46.00	-32.93	AVG	P	
6	1.6980	19.49	10.27	29.76	56.00	-26.24	peak	P	
7	2.5530	18.41	10.05	28.46	56.00	-27.54	peak	P	
8	2.5530	1.88	10.05	11.93	46.00	-34.07	AVG	P	
9	9.7620	21.64	8.47	30.11	60.00	-29.89	peak	P	
10	9.7620	15.07	8.47	23.54	50.00	-26.46	AVG	P	
11	15.6390	21.30	9.25	30.55	60.00	-29.45	peak	P	
12	16.1970	6.78	9.33	16.11	50.00	-33.89	AVG	P	

Remark:

1. All readings are Quasi-Peak and Average values
2. Margin = Result (Result = Reading + Factor) - Limit
3. Factor = Insertion loss + Cable loss

Temperature:	21 °C	Relative Humidity:	43%
Phase:	N	Test Mode:	Mode 1
Test Voltage:	AC 230V/50Hz	Test Date:	2023.01.18

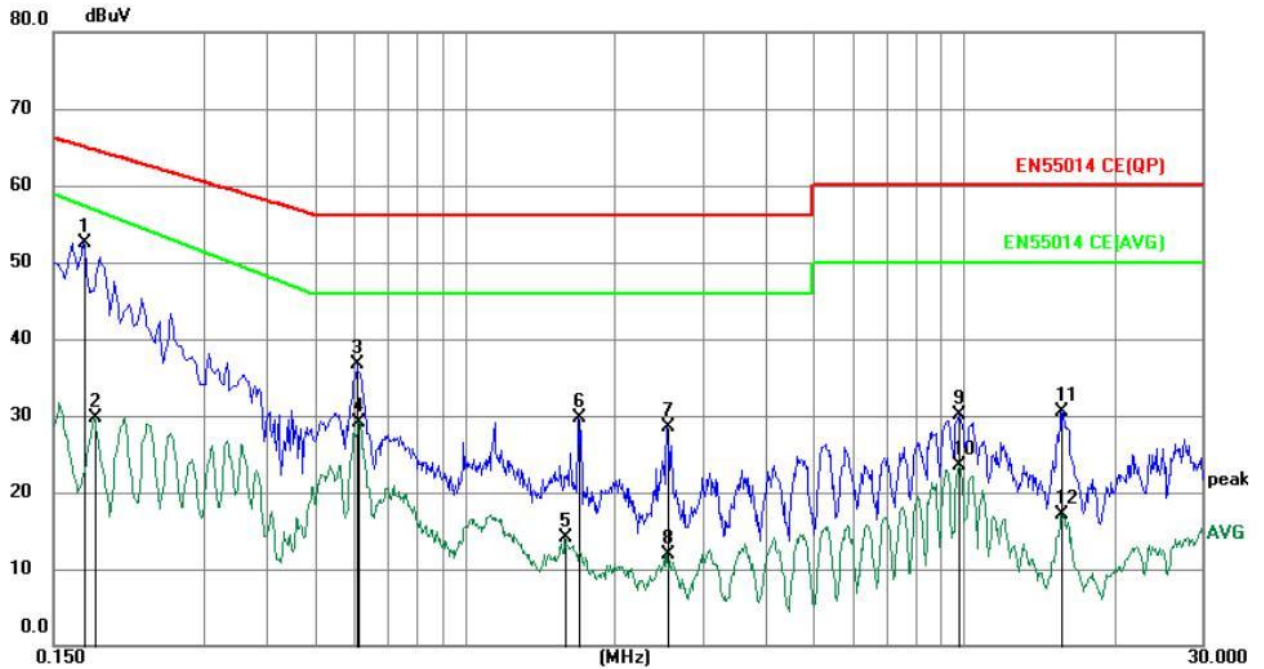

No.	Frequency (MHz)	Reading (dBuV)	Factor (dB)	Level (dBuV)	Limit (dBuV)	Margin (dB)	Detector	P/F	Remark
1	0.1725	40.07	12.51	52.58	64.84	-12.26	peak	P	
2	0.1815	17.28	12.33	29.61	56.94	-27.33	AVG	P	
3	0.6090	26.16	10.52	36.68	56.00	-19.32	peak	P	
4	0.6134	18.66	10.52	29.18	46.00	-16.82	AVG	P	
5	1.5855	3.74	10.29	14.03	46.00	-31.97	AVG	P	
6	1.6980	19.49	10.27	29.76	56.00	-26.24	peak	P	
7	2.5530	18.41	10.05	28.46	56.00	-27.54	peak	P	
8	2.5530	1.88	10.05	11.93	46.00	-34.07	AVG	P	
9	9.7620	21.64	8.47	30.11	60.00	-29.89	peak	P	
10	9.7620	15.07	8.47	23.54	50.00	-26.46	AVG	P	
11	15.6390	21.30	9.25	30.55	60.00	-29.45	peak	P	
12	15.6390	7.83	9.25	17.08	50.00	-32.92	AVG	P	

Remark:

1. All readings are Quasi-Peak and Average values
2. Margin = Level (Level = Reading + Factor) - Limit
3. Factor = Insertion loss + Cable loss

3.2 RADIATED EMISSION MEASUREMENT

3.2.1 LIMITS OF THE RADIATED EMISSION MEASUREMENT(Below 1000MHz)

FREQUENCY (MHz)	Class A		Class B	
	At 10m	At 3m	At 10m	At 3m
	dBuV/m	dBuV/m	dBuV/m	dBuV/m
30 – 230	40	50	30	40
230 – 300	47	57	37	47
230– 1000	47	57	37	47

Notes:

- (1) The limit for radiated test was performed in the following: CISPR 32.
- (2) The tighter limit applies at the band edges.
- (3) Emission level (dBuV/m)=20log Emission level (uV/m).

3.2.2 TEST PROCEDURE

- a. The EUT was placed on the top of a rotating table 0.8 meters above the ground at a 3 meter semi-anechoic chamber room. The table was rotated 360 degrees to determine the position of the highest radiation.
- b. EUT as the center to the edge of the auxiliary device, the distance from the maximum edge to the center of the antenna is 3 meters.
- c. The height of antenna is varied from 1 meter to 4 meters above the ground to determine the maximum value of the field strength. Both horizontal and vertical polarizations of the antenna are set to make the measurement.
- d. For each suspected emission, the EUT was arranged to its worst case and then the antenna was tuned to heights from 1 meter to 4 meters and the rotatable table was turned from 0 degrees to 360 degrees to find the maximum reading.
- e. The test-receiver system was set to quasi-peak detect function and specified bandwidth with maximum hold mode when the test frequency is below 1GHz.
- f. For the actual test configuration, please refer to the related Item –EUT Test Photos.

3.2.3 TEST SETUP

(A) Radiated Emission Test Set-Up Frequency Below 1 GHz

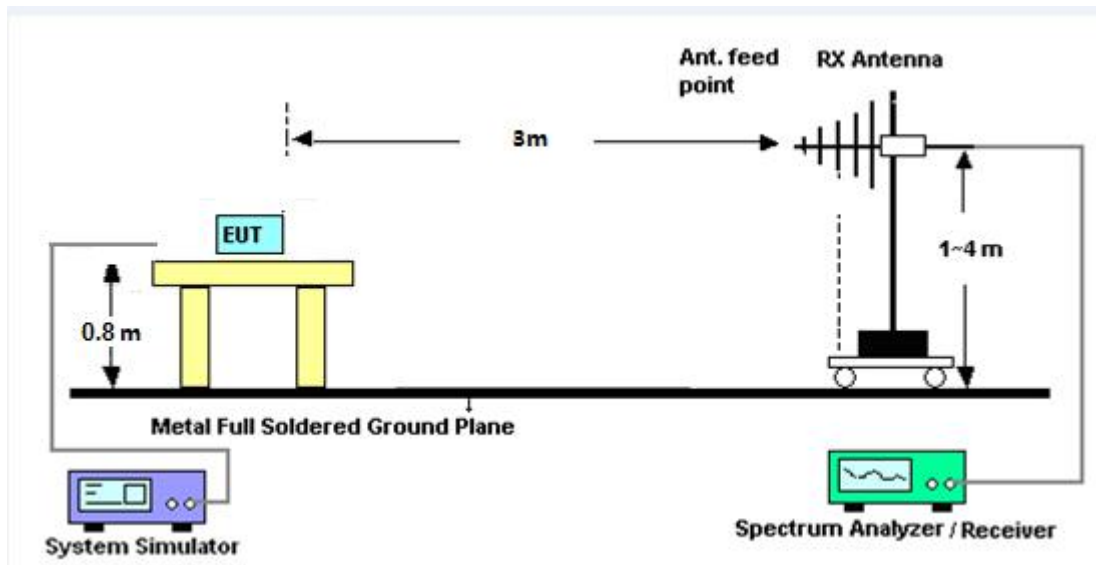

3.2.4 EUT OPERATING CONDITIONS

The EUT tested system was configured as the statements of 2.3 Unless otherwise a special operating condition is specified in the following during the testing.

3.2.5 TEST RESULTS

Temperature:	22°C	Relative Humidity:	47%
Phase:	Horizontal	Test Mode:	Mode 1
Test Voltage:	AC230V/50Hz	Test Date:	2023.01.18

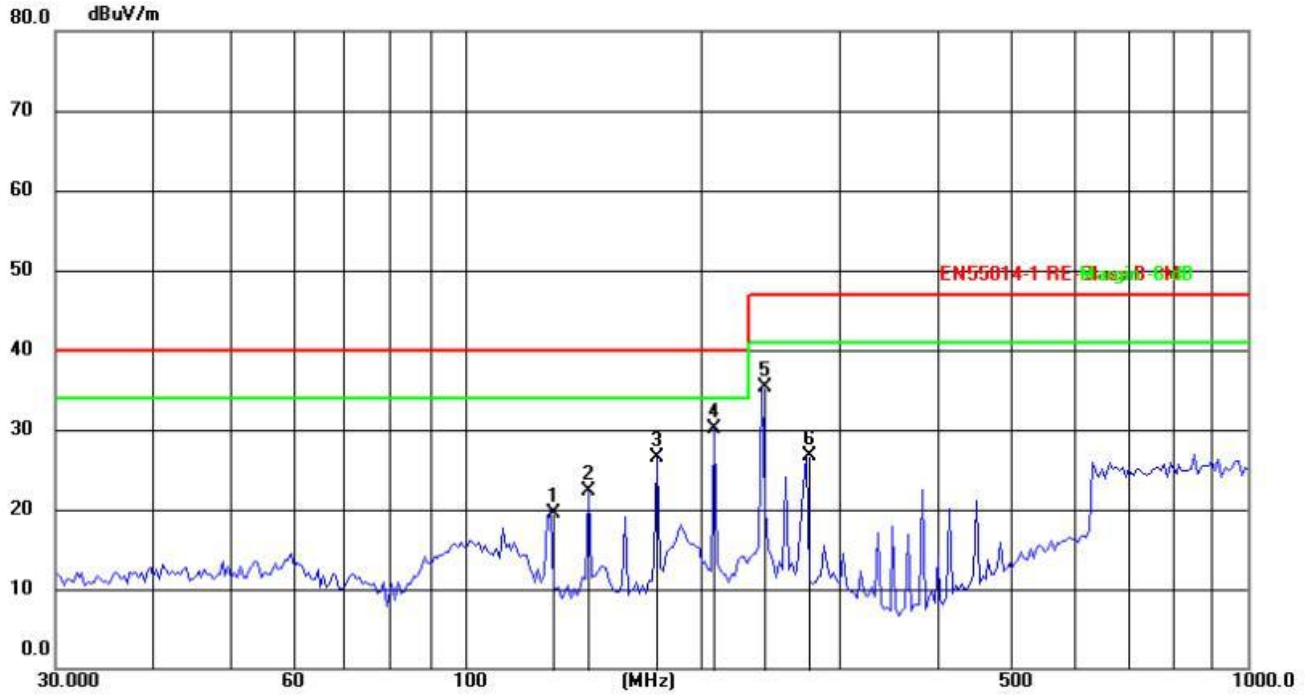

No.	Frequency (MHz)	Reading (dBuV)	Factor (dB/m)	Level (dBuV/m)	Limit (dBuV/m)	Margin (dB)	Detector	Height (cm)	Azimuth (deg.)	P/F	Remark
1	128.5630	37.61	-18.16	19.45	40.00	-20.55	peak				
2	144.0819	39.52	-17.23	22.29	40.00	-17.71	peak				
3	176.2686	44.71	-18.30	26.41	40.00	-13.59	peak				
4	208.2148	49.61	-19.46	30.15	40.00	-9.85	peak				
5	239.5670	53.02	-17.70	35.32	47.00	-11.68	peak				
6	273.2341	43.15	-16.48	26.67	47.00	-20.33	peak				

Remark:

1. All readings are Quasi-Peak and Average values
2. Margin = Result (Result = Reading + Factor) - Limit
3. Factor = Insertion loss + Cable loss

Temperature:	22°C	Relative Humidity:	47%
Phase:	Vertical	Test Mode:	Mode 1
Test Voltage:	AC230V/50Hz	Test Date:	2023.01.18

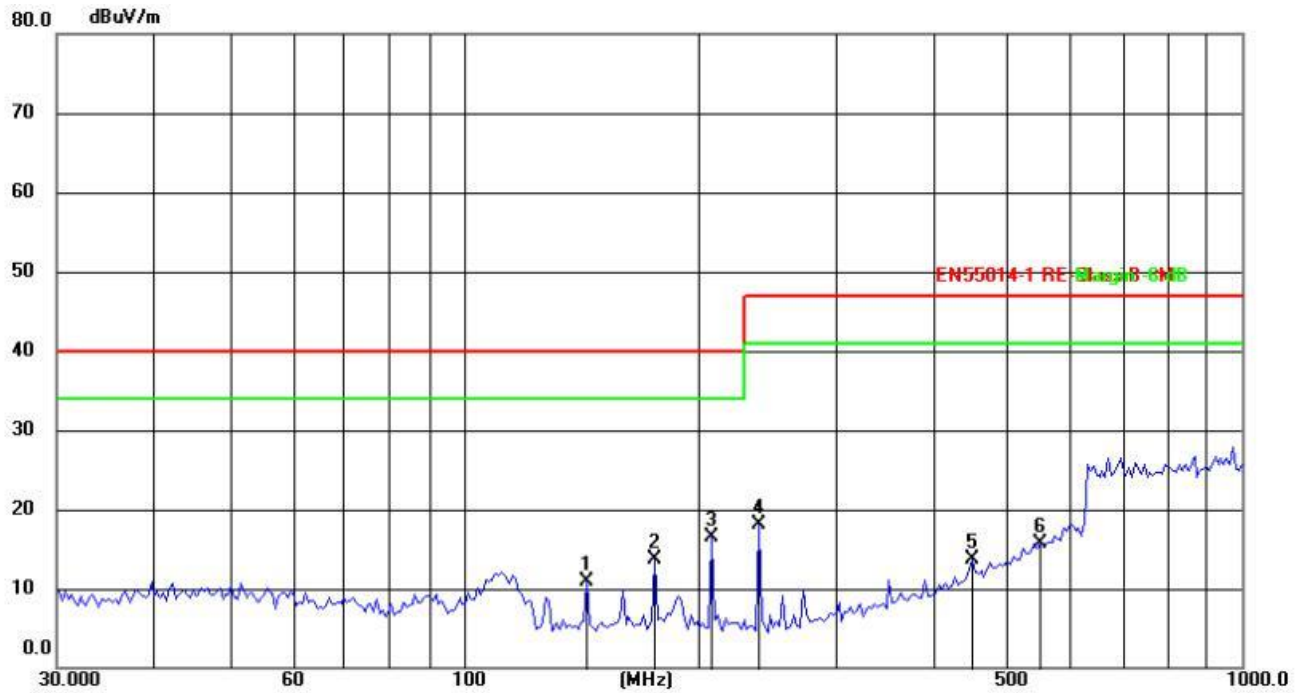

No.	Frequency (MHz)	Reading (dBuV)	Factor (dB/m)	Level (dBuV/m)	Limit (dBuV/m)	Margin (dB)	Detector	Height (cm)	Azimuth (deg.)	P/F	Remark
1	144.0819	32.15	-21.23	10.92	40.00	-29.08	peak				
2	176.2686	34.45	-20.67	13.78	40.00	-26.22	peak				
3	208.2148	38.11	-21.65	16.46	40.00	-23.54	peak				
4	239.5669	39.76	-21.67	18.09	47.00	-28.91	peak				
5	450.3447	28.91	-15.30	13.61	47.00	-33.39	peak				
6	550.9480	27.37	-11.64	15.73	47.00	-31.27	peak				

Remark:

1. All readings are Quasi-Peak and Average values
2. Margin = Level (Level = Reading + Factor) – Limit
3. Factor = Insertion loss + Cable loss

3.3 HARMONICS CURRENT

3.3.1 LIMITS OF THE HARMONICS CURRENT

IEC 555-2					
Table - I			Table - II		
Equipment Category	Harmonic Order n	Max. Permissible Harmonic Current (in Amperes)	Equipment Category	Harmonic Order n	Max. Permissible Harmonic Current (in Amperes)
Non Portable Tools or TV Receivers	Odd Harmonics		TV Receivers	Odd Harmonics	
	3	2.30		3	0.80
	5	1.14		5	0.60
	7	0.77		7	0.45
	9	0.40		9	0.30
	11	0.33		11	0.17
	13	0.21		13	0.12
	15 ≤ n ≤ 39	0.15 · 15/n		15 ≤ n ≤ 39	0.10 · 15/n
	Even Harmonics			Even Harmonics	
	2	1.08		2	0.30
4	0.43	4	0.15		
8	0.30				
8 ≤ n ≤ 40	0.23 · 8/n	DC	0.05		
	harmonics required		13 ≤ n ≤ 39	see Table I	3.85/n
			only odd harmonics required		

3.3.2 TEST PROCEDURE

a. The EUT was placed on the top of a wooden table 0.8 meters above the ground and operated to produce the maximum harmonic components under normal operating conditions.

b. The classification of EUT is according to section 5 of EN 61000-3-2. The EUT is classified as follows:

Class A: Balanced three-phase equipment, Household appliances excluding equipment as Class D, Tools excluding portable tools, Dimmers for incandescent lamps, audio equipment, equipment not specified in one of the three other classes.

Class B: Portable tools. Portable tools.; Arc welding equipment which is not professional equipment.

Class C: Lighting equipment.

Class D: Equipment having a specified power less than or equal to 600W of the following types: Personal computers and personal computer monitors and television receivers.

c. The correspondent test program of test instrument to measure the current harmonics emanated from EUT is chosen. The measure time shall be not less than the time necessary for the EUT to be exercised.

3.3.3 EUT OPERATING CONDITIONS

The EUT tested system was configured as the statements of 2.3 Unless otherwise a special operating condition is specified in the following during the testing.

3.3.4 TEST SETUP

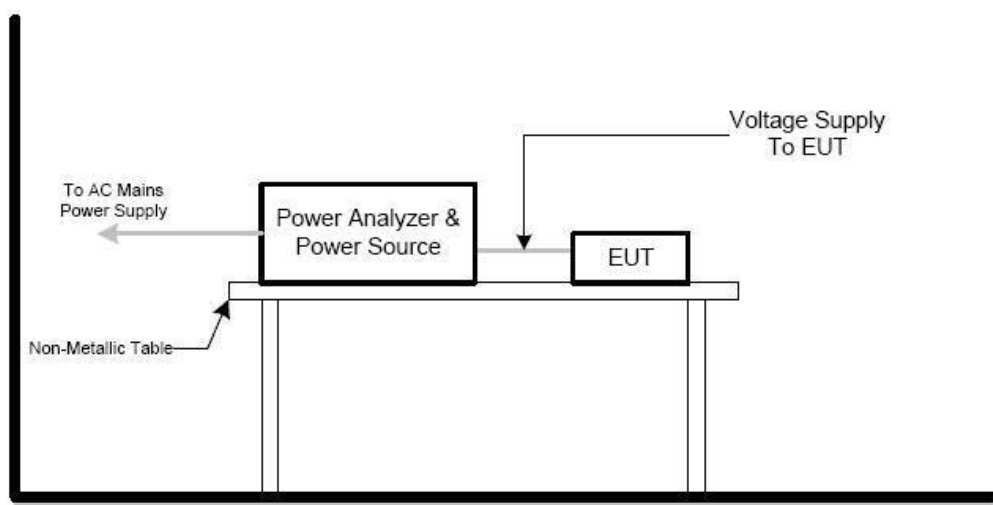

3.3.5 TEST RESULTS

Pass

Note: The EUT's rated power is less than 75W and does not belong to lighting equipment, therefore harmonic current test is not applicable in accordance with Clause 7 of EN IEC 61000-3-2:2019+A1.

3.4 VOLTAGE FLUCTUATION AND FLICKERS

3.4.1 LIMITS OF THE VOLTAGE FLUCTUATION AND FLICKERS

Tests	Measurement Value	Limit	Descriptions
	IEC555-3	IEC/EN 61000-3-3	
P _{st}	≤ 1.0, T _p = 10 min.	≤ 1.0, T _p = 10 min.	Short Term Flicker Indicator
P _{lt}	N/A	≤0.65, T _p =2 hr.	Long Term Flicker Indicator
T _{dt(s)}	≤ 3%	≤ 3.3%	Relative Steady-State V-Chang
d _{max} (%)	≤ 4%	≤ 4%	Maximum Relative V-Chang
d _c (%)	N/A	≤3.3% for > 500ms	Relative V-change Characteristic

3.4.2 TEST PROCEDURE

b. Fluctuation and Flickers Test:

Tests was performed according to the Test Conditions/Assessment of Voltage Fluctuations specified in Clause 5.0/6.0 of IEC555-3 and/or Clause 6.0/4.0 of IEC/EN 61000-3-3 depend on which standard adopted for compliance measurement.

c. All types of voltage fluctuation in this report are assessed by direct measurement using flicker-meter.

3.4.3 EUT OPERATING CONDITIONS

The EUT tested system was configured as the statements of 2.3 Unless otherwise a special operating condition is specified in the following during the testing.

3.4.4 TEST SETUP

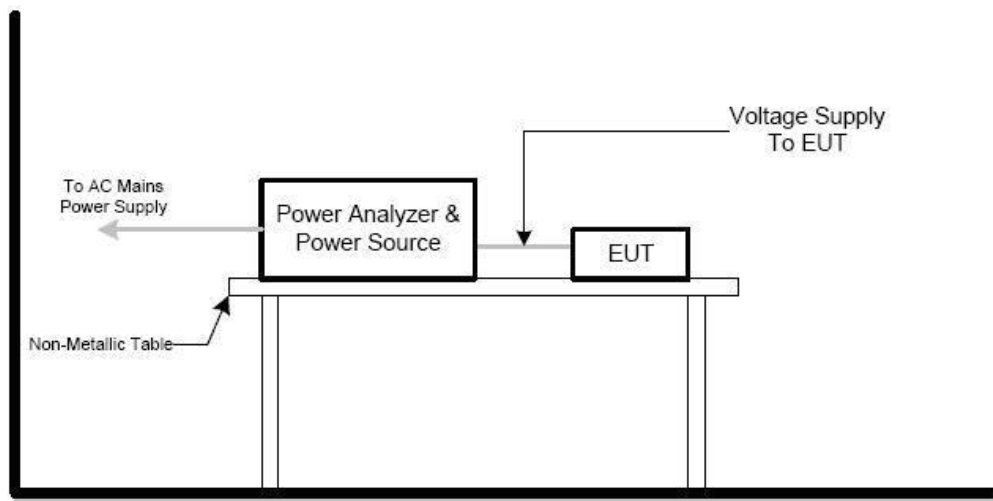

3.4.5 TEST RESULTS

Pass

The maximum active input power of the EUT is around 12W, which unlikely to produce significant voltage fluctuation. Therefore no test was applied.

See clause 6.1***

*** EN 61000-3-3:2013+A1+A2, clause 6.1:” ... Tests need not be made on equipment which is unlikely to produce significant voltage fluctuations or flicker. ...

4. EMC IMMUNITY TEST

4.1 STANDARD COMPLIANCE/SERVRITY LEVEL/CRITERIA

Tests Standard No.	TEST SPECIFICATION	Test Mode Test Ports	Perform. Criteria
1. ESD IEC/EN 61000-4-2	8KV air discharge 4KV contact discharge	Direct Mode	B
	4KV HCP discharge 4KV VCP discharge	Indirect Mode	B
2. RS IEC/EN 61000-4-3	80 MHz to 1000 MHz, 1000Hz, 80%, AM modulated	Enclosure	A
2. EFT/Burst IEC/EN 61000-4-4	5/50ns Tr/Th 5KHz Repetition Freq.	Power Supply Port	B
	5/50ns Tr/Th 5KHz Repetition Freq.	CTL/Signal Data Line Port	B
3. Surges IEC/EN 61000-4-5	1.2/50(8/20) Tr/Th us	L-N	B
	1.2/50(8/20) Tr/Th us	L-PE N-PE	B
4. Injected Current IEC/EN 61000-4-6	0.15 MHz to 230 MHz, 1000Hz 80 % , AM Modulated 150Ω source impedance	CTL/Signal Port	A
	0.15 MHz to 230 MHz, 1000Hz 80 % , AM Modulated 150Ω source impedance	AC Power Port	A
	0.15 MHz to 230 MHz, 1000Hz 80 % , AM Modulated 150Ω source impedance	DC Power Port	A
5. Power Frequency Magnetic Field IEC/EN 61000-4-8	50Hz/60Hz	Enclosure	A
6. Volt. Interruptions Volt. Dips IEC/EN 61000-4-11	Voltage dip 100%	AC Power Port	C
	Voltage dip 30%		C
	Voltage dip 60%		C

4.2 GENERAL PERFORMANCE CRITERIA

According to EN 55014-2 standard, the general performance criteria as following:

<p>Criterion A</p>	<p>The apparatus shell continues to operate as intended without operator intervention. No degradation of performance or loss of function is allowed below a performance level specified by the manufacturer, when the apparatus is used as intended. The performance level may be replaced by a permissible loss of performance. If the manufacturer does not specify the minimum performance level or the permissible performance loss, then either of these may be derived from the product description and documentation, and by what the user may reasonably expect from the equipment if used as intended.</p>
<p>Criterion B</p>	<p>After test, the apparatus shell continues to operate as intended without operator intervention. No degradation of performance or loss of function is allowed, after the application of the phenomenon below a performance level specified by the manufacturer, when the apparatus is used as intended. The performance level may be replaced by a permissible loss of performance.</p> <p>During the test, degradation of performance is however allowed. However, no change of operating state if stored data is allowed to persist after the test. If the manufacturer does not specify the minimum performance level or the permissible performance loss, then either of these may be derived from the product description and documentation, and by what the user may reasonably expect from the equipment if used as intended.</p>
<p>Criterion C</p>	<p>Temporary loss of function is allowed, provided the functions is self-recoverable or can be restored by the operation of controls by the user in accordance with the manufacturer instructions.</p> <p>Functions, and/or information stored in non-volatile memory, or protected by a battery backup, shall not be lost.</p>

4.2.1 GENERAL PERFORMANCE CRITERIA TEST SETUP

The EUT tested system was configured as the statements of 2.3 Unless otherwise a special operating condition is specified in the following during the testing.

4.3 ELECTROSTATIC DISCHARGE IMMUNITY TEST (ESD)

4.3.1 TEST SPECIFICATION

Basic Standard:	IEC/EN 61000-4-2
Discharge Impedance:	330 ohm / 150 pF
Required Performance:	B
Discharge Voltage:	Air Discharge : 2KV/4KV/8KV (Direct) Contact Discharge : 2KV/4KV (Direct/Indirect)
Polarity:	Positive & Negative
Number of Discharge:	Air Discharge: min. 20 times at each test point Contact Discharge: 10 with positive and 10 with negative polarity
Discharge Mode:	Single Discharge
Discharge Period:	1 second minimum

4.3.2 TEST PROCEDURE

The test generator necessary to perform direct and indirect application of discharges to the EUT in the following manners:

- a. Electrostatic discharges were applied only to those points and surfaces of the EUT that are accessible to users during normal operation
The test was performed with at least ten single discharges on the pre-selected points in the most sensitive polarity.

The time interval between two successive single discharges was at least 1 second.

The ESD generator was held perpendicularly to the surface to which the discharge was applied and the return cable was at least 0.2 meters from the EUT.

Contact discharges were applied to the non-insulating coating, with the pointed tip of the generator penetrating the coating and contacting the conducting substrate.

Air discharges were applied with the round discharge tip of the discharge electrode approaching the EUT as fast as possible (without causing mechanical damage) to touch the EUT. After each discharge, the ESD generator was removed from the EUT and re-triggered for a new single discharge. The test was repeated until all discharges were complete.

Vertical Coupling Plane (VCP):

The coupling plane of dimensions 0.5m x 0.5m, is placed parallel to and positioned at a distance 0.1m from the EUT, with the Discharge Electrode touching the coupling plane. The four faces of the EUT will be performed with electrostatic discharge.

Horizontal Coupling Plane (HCP):

The coupling plane is placed under to the EUT. The generator shall be positioned vertically at a distance of 0.1m from the EUT, with the Discharge Electrode touching the coupling plane. The four faces of the EUT will be performed with electrostatic discharge.

- b. Air discharges at insulation surfaces of the EUT.
It was at least ten single discharges with positive and negative at the same selected point.

4.3.3 TEST SETUP

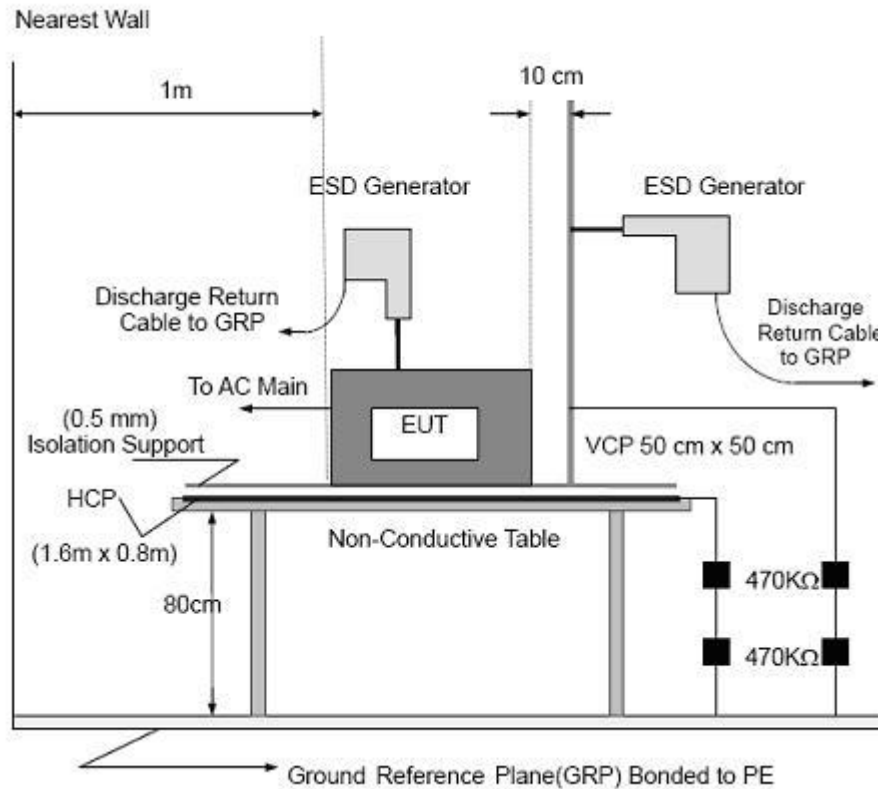

Note:

TABLE-TOP EQUIPMENT

The configuration consisted of a wooden table 0.8 meters high standing on the Ground Reference Plane. The GRP consisted of a sheet of aluminum at least 0.25mm thick. A Horizontal Coupling Plane (1.6m x 0.8m) was placed on the table and attached to the GRP by means of a cable with 940kΩ total impedance. The equipment under test, was installed in a representative system as described in section 7 of IEC /EN 61000-4-2, and its cables were placed on the HCP and isolated by an insulating support of 0.5mm thickness. A distance of 0.8-meter minimum was provided between the EUT and the walls of the laboratory and any other metallic structure.

FLOOR-STANDING EQUIPMENT

The equipment under test was installed in a representative system as described in section 7 of IEC/EN 61000-4-2, and its cables were isolated from the Ground Reference Plane by an insulating support of 0.1meter thickness. The GRP was consisted of a sheet of aluminum that is at least 0.25mm thick, and extended at least 0.5 meters from the EUT on all sides.

4.3.4 TEST RESULTS

Temperature:	22°C	Relative Humidity:	55%
Pressure:	1010hPa	Test Voltage:	AC 230V/50Hz
Test Mode:	Mode 1	Test Date:	2023.01.18

Discharge Level	Polarity	Test Points	Contact Discharge	Air Discharge	Criterion	Test Result
4	+/-	VCP/HCP	NOTE	N/A	A	PASS
2,4	+/-	Green Dot	NOTE	N/A	A	PASS
2,4,8	+/-	Red Dot	N/A	NOTE	A	PASS

Note: The EUT function was correct during the test
 Red Dot —Air Discharged
 Green Dot —Contact Discharged

Note: 1) N/A - denotes test is not applicable in this test report.

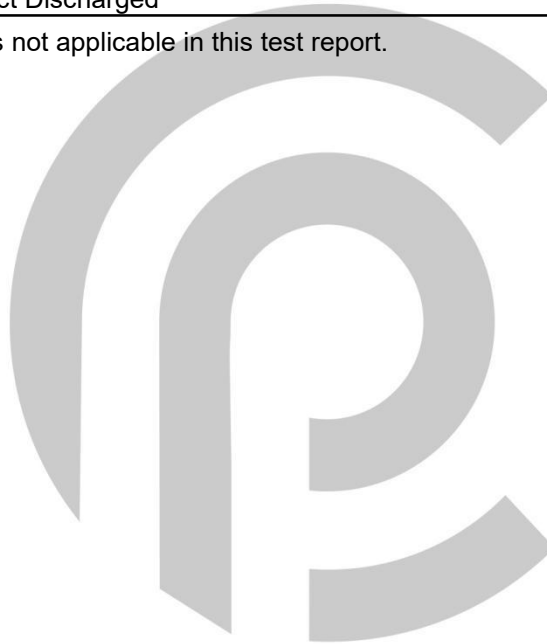

The Photo for Discharge Points of EUT

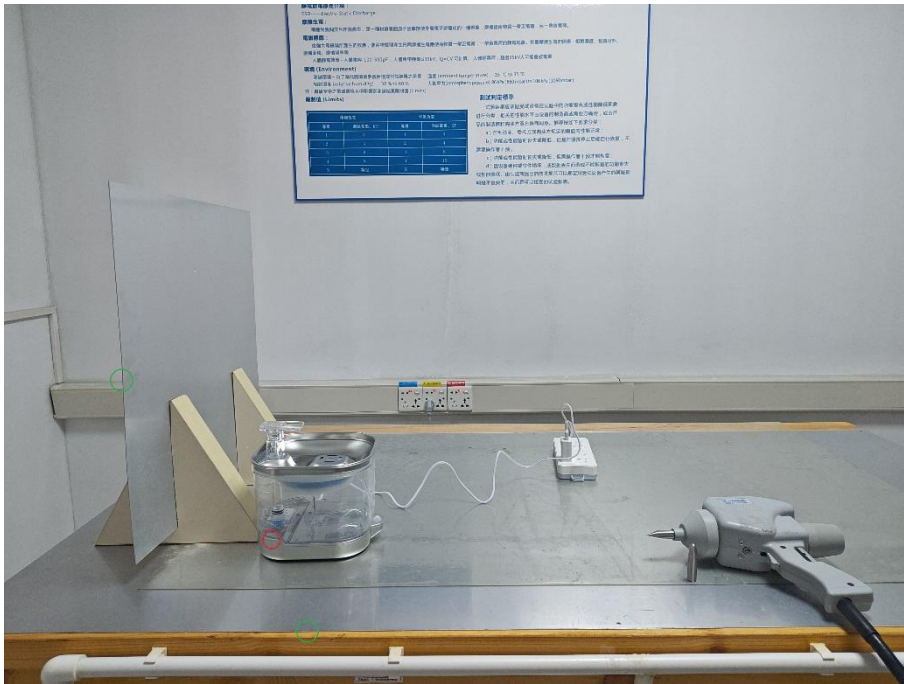

4.4 RADIATED, RADIO-FREQUENCY, ELECTROMAGNETIC FIELD IMMUNITY TEST(RS)

4.4.1 TEST SPECIFICATION

Basic Standard:	IEC/EN 61000-4-3
Required Performance:	A
Frequency Range:	80 MHz - 1000 MHz
Field Strength:	3 V/m
Modulation:	1kHz Sine Wave, 80%, AM Modulation
Frequency Step:	1 % of fundamental
Polarity of Antenna:	Horizontal and Vertical
Test Distance:	3 m
Antenna Height:	1.5 m
Dwell Time:	1.5x 10 ⁻³ decade/s

4.4.2 TEST PROCEDURE

- The testing was performed in a fully anechoic chamber. The transmit antenna was located at a distance of 3 meters from the EUT.
- The frequency range is swept from 80 MHz to 1000 MHz, with the signal 80% amplitude modulated with a 1kHz sine-wave. The rate of sweep did not exceed 1.5×10^{-3} decade/s, where the frequency range is swept incrementally, the step size was 1% of preceding frequency value.
- The dwell time at each frequency shall be not less than the time necessary for the EUT to be able to respond.
- The test was performed with the EUT exposed to both vertically and horizontally polarized fields on each of the four sides.

4.4.3 TEST SETUP

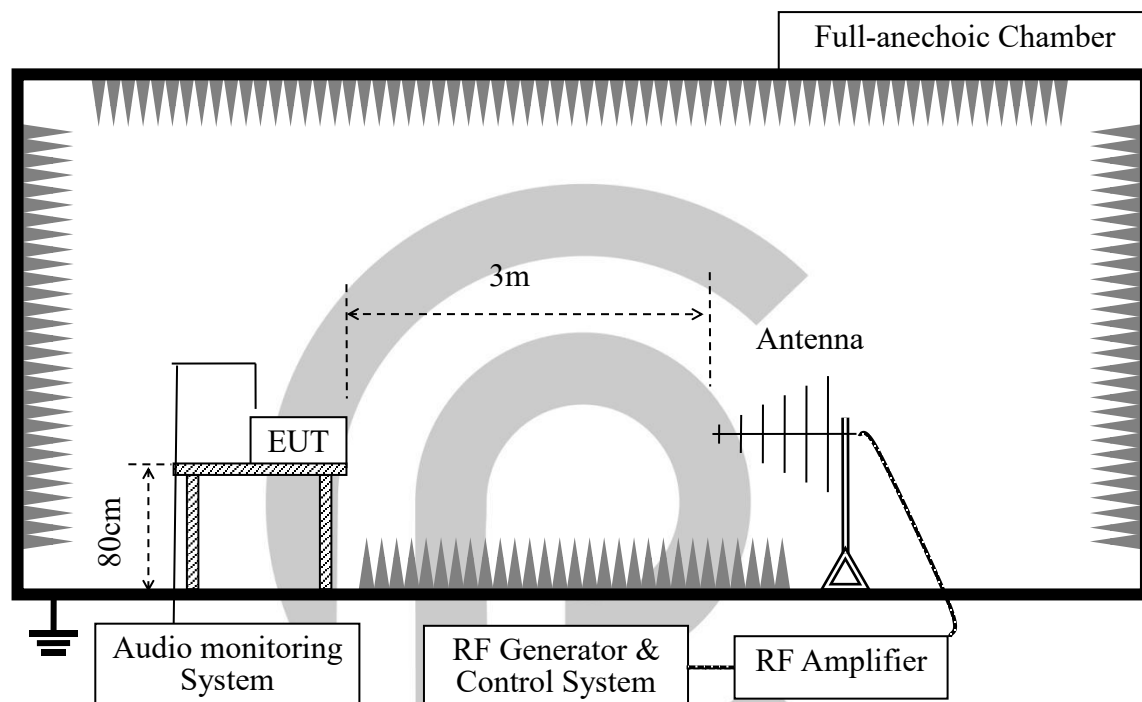

Note:

TABLE-TOP EQUIPMENT

The EUT installed in a representative system as described in section 7 of IEC/EN 61000-4-3 was placed on a non-conductive table 0.8 meters in height. The system under test was connected to the power and signal wire according to relevant installation instructions.

FLOOR-STANDING EQUIPMENT

The EUT installed in a representative system as described in section 7 of IEC/EN 61000-4-3 was placed on a non-conductive wood support 0.1 meters in height. The system under test was connected to the power and signal wire according to relevant installation instructions.

4.4.4 TEST RESULTS

Temperature:	23.9°C	Relative Humidity:	52%
Test Voltage:	AC 230V/50Hz	Test Date:	2023.01.18
Test Mode: Mode1			

Frequency Range (MHz)	RF Field Position	R.F. Field Strength	Azimuth	Perform. Criteria	Results	Judgment
80MHz - 1000MHz	H / V	3 V/m (rms) AM Modulated 1000Hz, 80%	Front	A	A	PASS
			Rear			
			Left			
			Right			

Note: 1) N/A - denotes test is not applicable in this test report.



4.5 ELECTRICAL FAST TRANSIENT (EFT)

4.5.1 TEST SPECIFICATION

Basic Standard:	IEC/EN 61000-4-4
Required Performance:	B
Test Voltage:	Power Line: 1 KV Signal/Control Line: 0.5 KV
Polarity:	Positive & Negative
Impulse Frequency:	5 kHz
Impulse Wave shape :	5/50 ns
Burst Duration:	15ms
Burst Period:	300ms
Test Duration:	Not less than 2 min.

4.5.2 TEST PROCEDURE

The ground reference plane shall be a metallic sheet (copper or aluminum) of 0.25 mm minimum thickness; other metallic materials may be used, but they shall have at least 0.65 mm minimum thickness.

The other condition need as following manners:

- a. The length of power cord between the coupling device and the EUT should not exceed 1 meter.
- b. Both positive and negative polarity discharges were applied.
- c. The duration time of each test sequential was 2 minute.

4.5.3 TEST SETUP

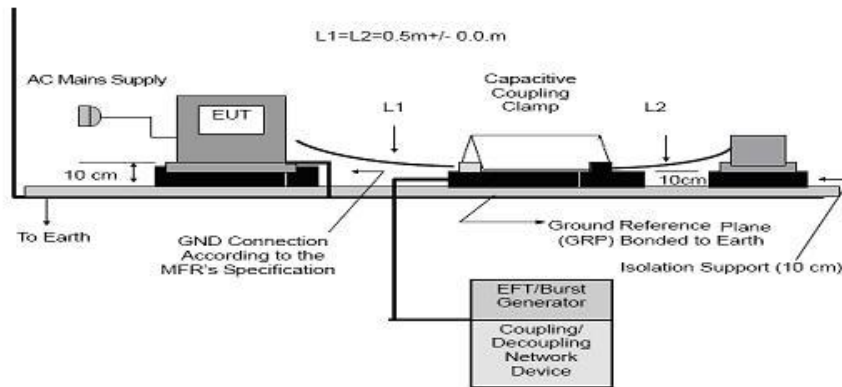
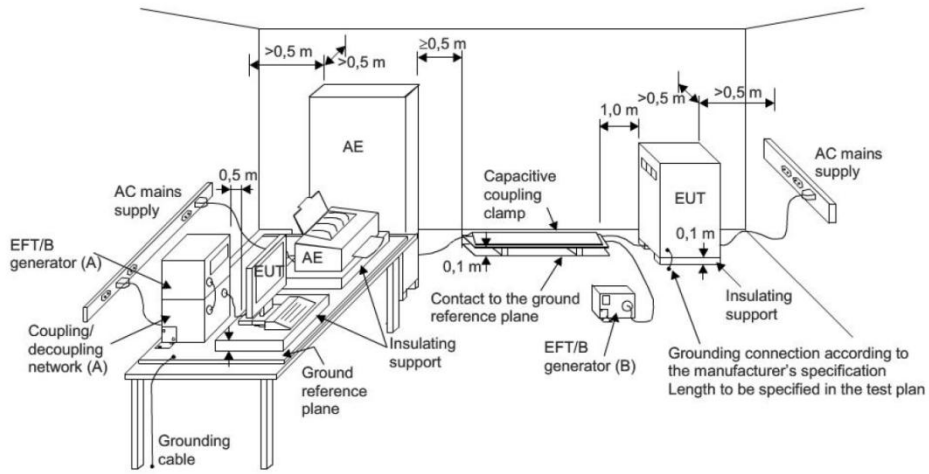

Note:

TABLE-TOP EQUIPMENT

Table-top equipment and equipment normally mounted on ceilings or walls as well as built-in equipment shall be tested with the EUT located (0.1 ± 0.01) m above the ground reference plane. Testing of large table-top equipment or multiple systems can be performed on the floor; maintaining the same distances as for the test setup of table-top equipment.

The test generator and the coupling/decoupling network shall be bonded to the ground reference plane.

The ground reference plane shall be a metallic sheet (copper or aluminum) of 0.25mm minimum thickness; other metallic materials may be used, but they shall have at least 0.65 mm minimum thickness.

The minimum size of the ground reference plane is 0.8m x 1m. The actual size depends on the dimensions of the EUT.

The ground reference plane shall project beyond the EUT by at least 0.1m on all sides.

The ground reference plane shall be connected to the earth (PE) for safety reasons.

The EUT shall be arranged and connected to satisfy its functional requirements, according to the equipment installation specifications.

The minimum distance between the EUT and all other conductive structures (including the generator, AE and the walls of a shielded room), except the ground reference plane, shall be more than 0.5m.

All cables to the EUT shall be placed on the insulation support 0.1m above the ground reference plane. Cables not subject to electrical fast transients shall be routed as far as possible from the cable under test to minimize the coupling between the cables.

The EUT shall be connected to the earth system in accordance with the manufacturer's installation specifications; no additional earth connections are allowed.

The connection impedance of the coupling/decoupling network earth cables to the ground reference plane and all connectors shall provide a low inductance.

Either a direct coupling network or a capacitive clamp shall be used for the application of the test voltages. The test voltages shall be coupled to all of the EUT ports in turn including those between two units of equipment involved in the test, unless the length of the interconnecting cable makes it impossible to test.

FLOOR-STANDING EQUIPMENT

When using the coupling clamp, the minimum distance between the coupling plates and all other conductive surfaces (including the generator), except the ground reference plane beneath the coupling clamp and beneath the EUT, shall be at least 0.5m.

The distance between any coupling devices and the EUT shall be $(0.5 - 0/+0.1)$ m for tabletop equipment testing, and (1.0 ± 0.1) m for floor standing equipment, unless otherwise specified in product standards. When it is not physically possible to apply the distances mentioned above, other distances can be used and shall be recorded in the test report.

The cable between the EUT and the coupling device, if detachable, shall be as short as possible to comply with the requirements of this clause. If the manufacturer provides a cable exceeding the distance between the coupling device and the point of only of the EUT, the excess length of this cable shall be bundled and situated at a distance of 0,1m above the ground reference plane. When a capacitive clamp is used as a coupling device, the excess cable length shall be bundled at the AE side.

Parts of the EUT with interconnecting cables of a length less than 3m, which are not tested, shall be placed on the insulating support. The parts of the EUT shall have a distance of 0,5m between them. Excess cable length shall be bundled.

4.5.4 TEST RESULTS

Temperature:	23.9°C	Relative Humidity:	52%
Test Voltage:	AC 230V/50Hz	Test Date:	2023.01.18
Test Mode:	Mode 1		

Coupling Line		Test level	Perform. Criteria	Results	Judgment
ACline	L	± 1KV	B	A	PASS
	N	± 1KV		A	PASS
	PE	N/A		A	N/A
	L+N	± 1KV		A	PASS
	L+PE	N/A		A	N/A
	N+PE	N/A		A	N/A
	L+N+PE	N/A		A	N/A

Note: 1) N/A - denotes test is not applicable in this test report.

4.6 SURGE TESTING

4.6.1 TEST SPECIFICATION

Basic Standard:	IEC/EN 61000-4-5
Required Performance:	B
Wave-Shape:	Combination Wave 1.2/50us Open Circuit Voltage
Test Voltage:	Power line ~ line to line: 1 KV line to ground: 2KV
Surge Input/Output:	L-N, L-PE, N-PE
Generator Source:	2 ohm between networks
Impedance:	12 ohm between network and ground
Polarity:	Positive/Negative
Phase Angle:	0°/90°/180°/270°
Pulse Repetition Rate:	1 time / min. (maximum)
Number of Tests:	5 positive and 5 negative at selected points

4.6.2 TEST PROCEDURE

- a. For EUT power supply:
The surge is to be applied to the EUT power supply terminals via the capacitive coupling network. Decoupling networks are required in order to avoid possible adverse effects on equipment not under test that may be powered by the same lines, and to provide sufficient decoupling impedance to the surge wave. The power cord between the EUT and the coupling/decoupling networks shall be 2meters in length (or shorter).
- b. For test applied to unshielded unsymmetrical operated interconnection lines of EUT:
The surge is applied to the lines via the capacitive coupling. The coupling /decoupling networks shall not influence the specified functional conditions of the EUT. The interconnection line between the EUT and the coupling/decoupling networks shall be 2 meters in length (or shorter).

4.6.3 TEST SETUP

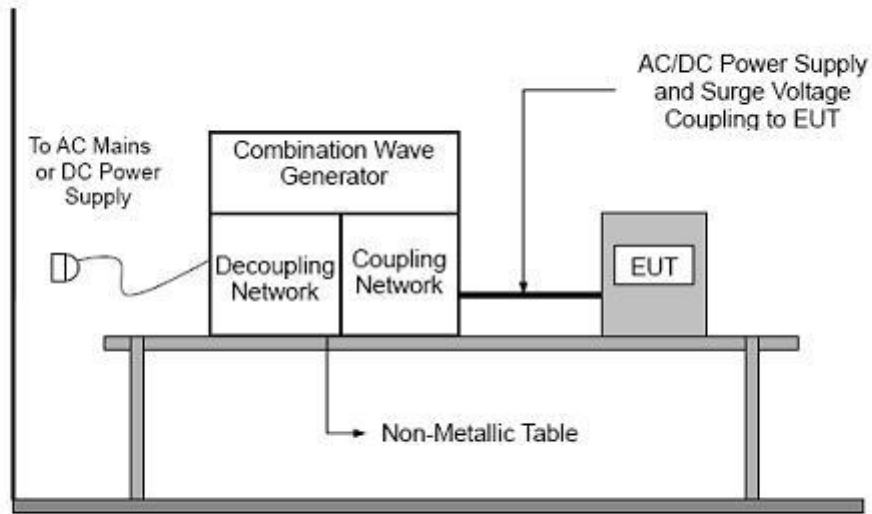

4.6.4 TEST RESULTS

Temperature:	22°C	Relative Humidity:	54%
Test Voltage:	AC 230V/50Hz	Test Date:	2023.01.18
Test Mode:	Mode 1		

Coupling Line		Test level	Perform. Criteria	Results	Judgment
AC Line	L-N	± 1KV	B	A	PASS
	L-PE	N/A		A	N/A
	N-PE	N/A		A	N/A

Note: 1) N/A - denotes test is not applicable in this test report.



4.7 CONDUCTED RADIO FREQUENCY DISTURBANCES (CS)

4.7.1 TEST SPECIFICATION

Basic Standard:	IEC/EN 61000-4-6
Required Performance:	A
Frequency Range:	0.15 MHz - 230 MHz
Field Strength:	3Vr.m.s.
Modulation:	1kHz Sine Wave, 80%, AM Modulation
Frequency Step:	1 % of fundamental
Dwell Time:	1.5×10^{-3} decade/s

4.7.2 TEST PROCEDURE

The EUT shall be tested within its intended operating and climatic conditions.

The test shall be performed with the test generator connected to each of the coupling and decoupling devices in turn, while the other non-excited RF input ports of the coupling devices are terminated by a 50-ohm load resistor.

The frequency range was swept from 150 kHz to 230 MHz, using the signal level established during the setting process and with a disturbance signal of 80 % amplitude. The signal was modulated with a 1 kHz sine wave, pausing to adjust the RF signal level or the switch coupling devices as necessary. The sweep rate was 1.5×10^{-3} decades/s. Where the frequency range is swept incrementally, the step size was 1 % of preceding frequency value from 150 kHz to 230 MHz.

The dwell time at each frequency was less than the time necessary for the EUT to be exercised, and able to respond. Sensitive frequencies such as clock frequency(ies) and harmonics or frequencies of dominant interest, was analyzed separately.

Attempts were made to fully exercise the EUT during testing, and to fully interrogate all exercise modes selected for susceptibility.

4.7.3 TEST SETUP

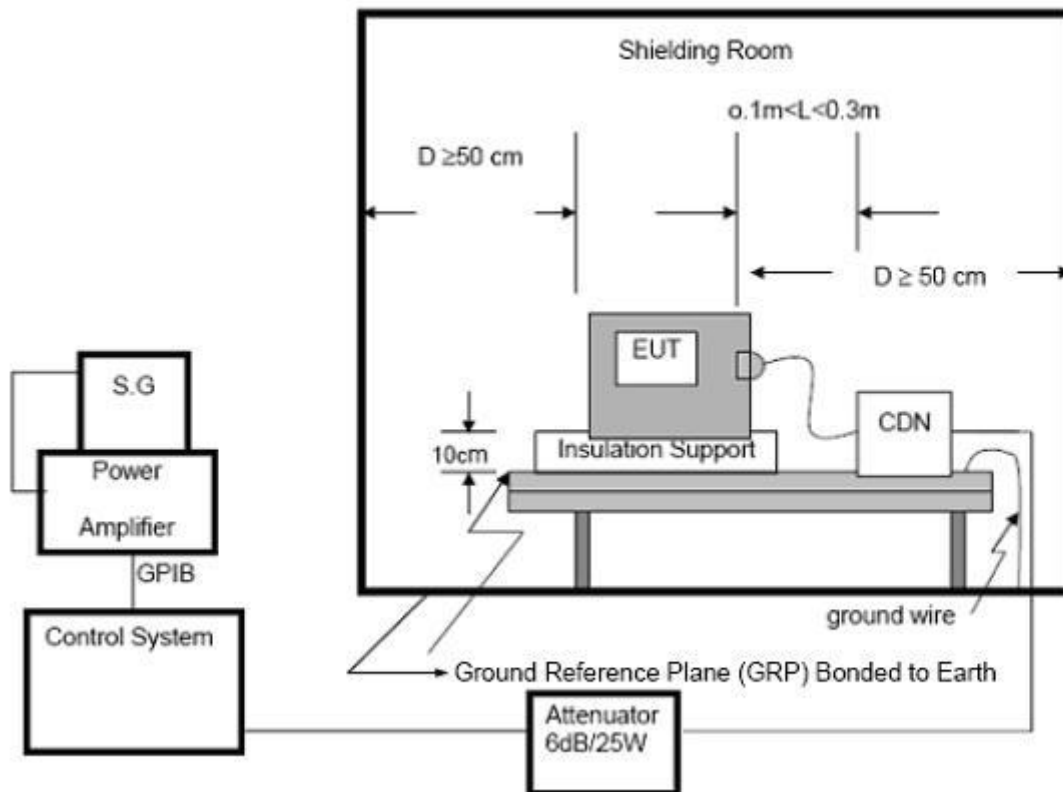

NOTE:

FLOOR-STANDING EQUIPMENT

The equipment to be tested is placed on an insulating support of 0.1 meters height above a ground reference plane. All relevant cables shall be provided with the appropriate coupling and decoupling devices at a distance between 0.1 meters and 0.3 meters from the projected geometry of the EUT on the ground reference plane.

4.7.4 TEST RESULTS

Temperature:	23.2°C	Relative Humidity:	52%
Test Voltage:	AC 230V/50Hz	Test Date:	2023.01.18
Test Mode:	Mode 1		

Test Ports (Mode)	Freq. Range (MHz)	Field Strength	Perform. Criteria	Results	Judgment
Input/ Output AC. Power Port	0.15 -230	3V(rms) AM Modulated 1000Hz, 80%	A	A	PASS
Input/ Output DC. Power Port	0.15 - 230		N/A	N/A	N/A
Signal Line	0.15 - 230		N/A	N/A	N/A

Note: 1) N/A - denotes test is not applicable in this test report.

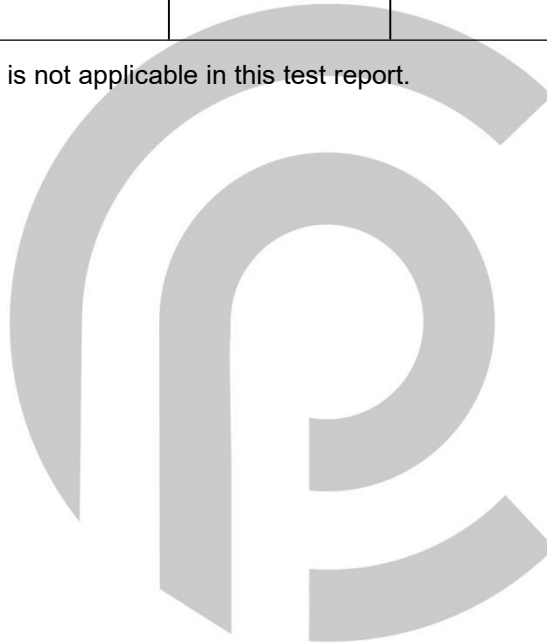

4.8 VOLTAGE INTERRUPTION/DIPS TESTING (DIPS)

4.8.1 TEST SPECIFICATION

Basic Standard:	IEC/EN 61000-4-11
Required Performance:	C (For 100% Voltage Dips, 0.5 Cycle) C (For 30% Voltage Dips, 25 Cycle) C (For 60% Voltage Dips, 10 Cycles)
Test Duration Time:	Minimum three test events in sequence
Interval between Event:	Minimum ten seconds
Phase Angle:	0°/45°/90°/135°/180°/225°/270°/315°/360°
Test Cycle:	3 times

4.8.2 TEST PROCEDURE

The EUT shall be tested for each selected combination of test levels and duration with a sequence of three dips/interruptions with intervals of 10 s minimum (between each test event). Each representative mode of operation shall be tested. Abrupt changes in supply voltage shall occur at zero crossings of the voltage waveform.

4.8.3 TEST SETUP

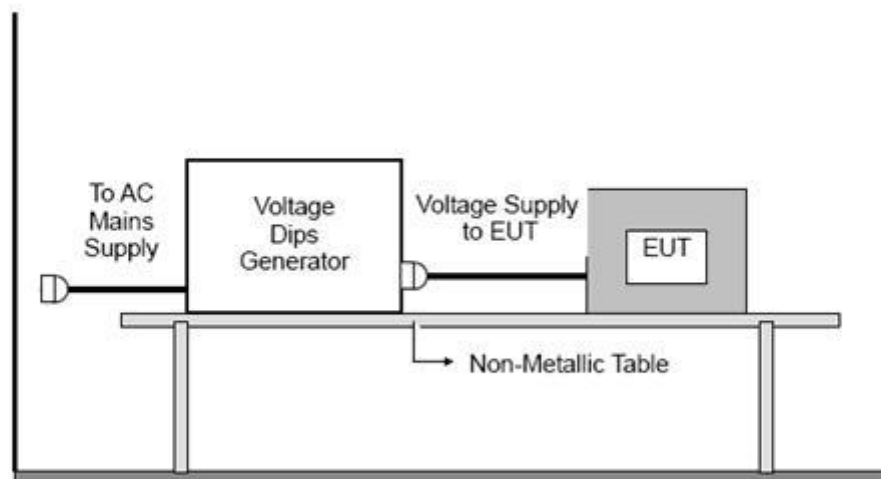

4.8.4 TEST RESULTS

Temperature:	25℃	Relative Humidity:	52%
Test Voltage:	AC230V/50Hz	Test Date:	2023.01.18
Test Mode:	Mode 1		

Voltage Reduction	Duration (cycle)	Perform Criteria	Results	Judgment
Voltage dip 100%	0.5	C	B	PASS
Voltage dip 30%	25	C	B	PASS
Voltage dip 60%	10	C	C	PASS



APPENDIX 1-TEST SETUP

Conducted Measurement Photo



Radiated Measurement Photo



ESD Measurement Photo

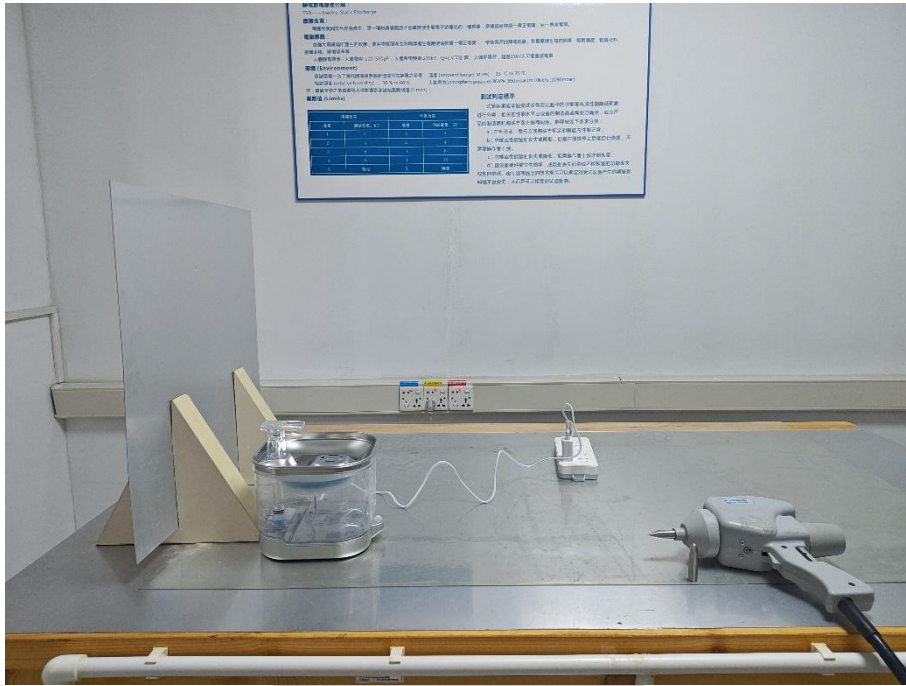

EFT Measurement Photo



SURGE Measurement Photo

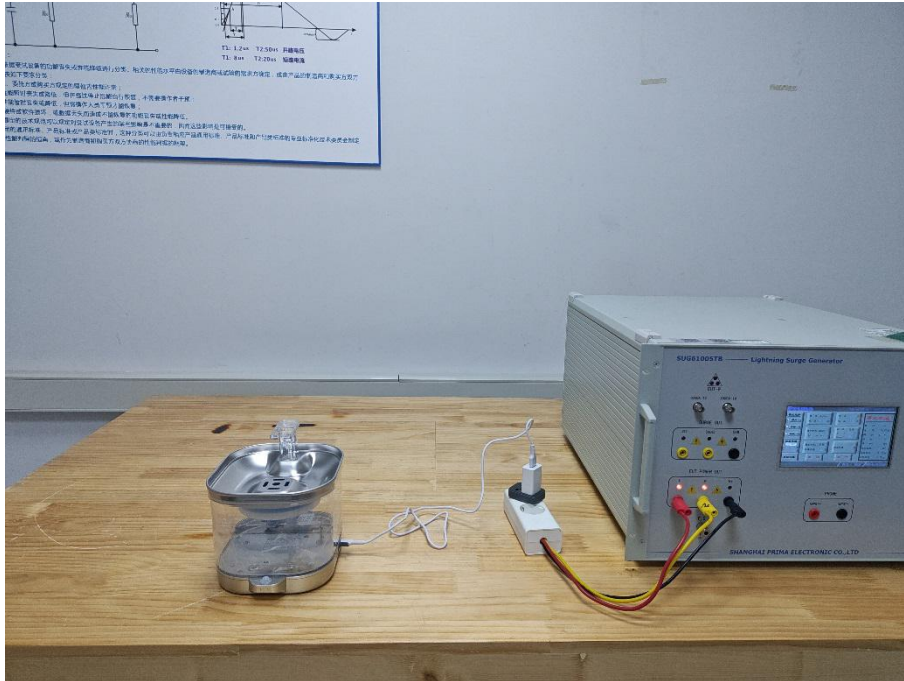

DIPS Measurement Photo



APPENDIX 2-PHOTOGRAPHS OF EUT CONSTRUCTIONAL DETAILS

Photo 1



Photo 2

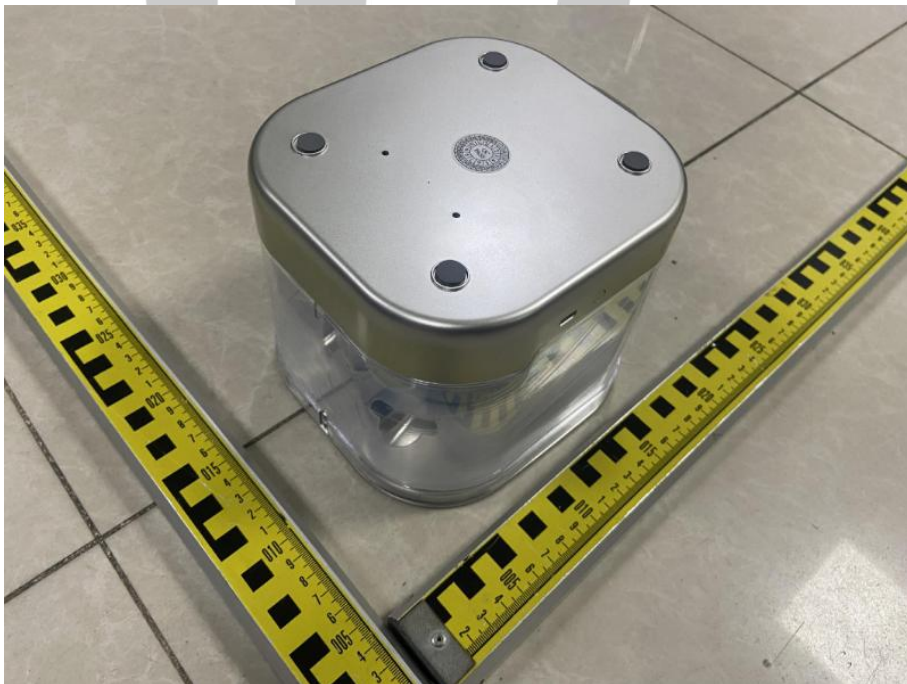

Photo 3



Photo 4



Photo 5

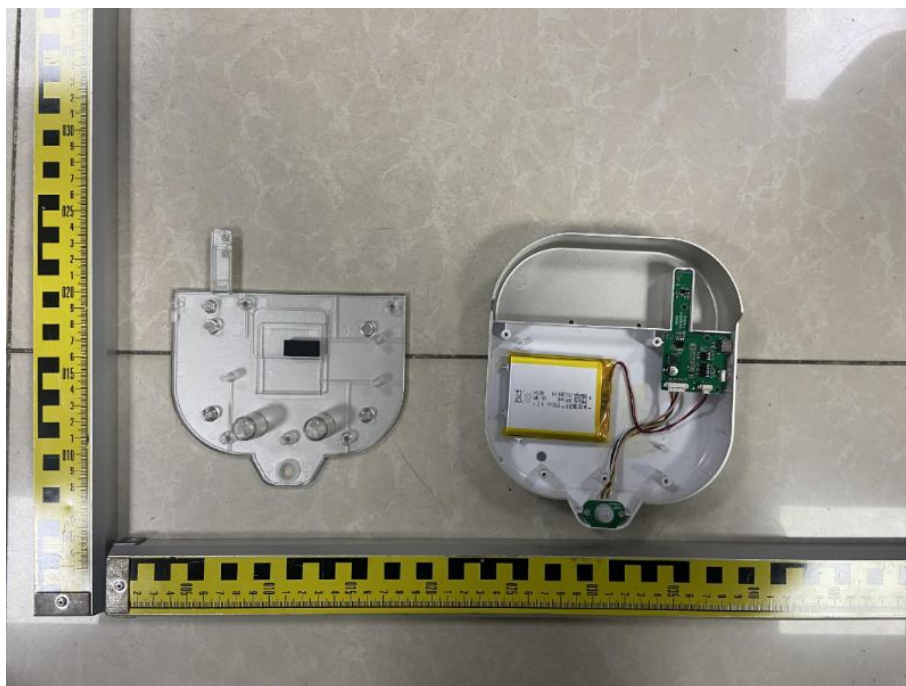

*****END OF THE REPORT*****