

EMC Test Report

Applicant's Name..... : Dongguan Zhiyihong hardware and Plastics Co., Ltd.
Address..... : Room 101, building 1, No.110, Humen Xinfeng Road, Humen TownDongguan City, Guangdong Province
Manufacturer's Name..... : Dongguan Zhiyihong hardware and Plastics Co., Ltd.
Address..... : Room 101, building 1, No.110, Humen Xinfeng Road, Humen TownDongguan City, Guangdong Province
Product Description
Product Name..... : Pet Water Dispenser
Model Name..... : WF060, WF040, WF050, WF020, WF020TP, WF020WH, WF050TP, WF070, WF080, WF090, WF100, WF110, WF120, WF130, WF140, WF150, WF160, WF170, WF180, WF190, WF200, WF210, WF220, WF230, WF030, WF240, WF250, WF260, WF270, WF280, WF290, WF300, WF310, WF320, WF330, WF340, WF350, WF360, WF370, WF380, WF390, WF400, WF410, WF420, WF430, WF440, WF450, WF460, WF470, WF480, WF490, WF500, WF510, WF520, WF530, WF540, WF550, WF560, WF570, WF580, WF590, WF600, WF610, WF620, WF630, WF640, WF650, WF660, WF670, WF680, WF690, WF700, WF710, WF720, WF730, WF740, WF750, WF760, WF770, WF780, WF790, WF800
Standards..... : FCC Part 15 Subpart B
ANSI C63.4: 2014

The above-mentioned equipment has passed the Promise test, and the test results show that the equipment under test (EUT) complies with FCC requirements. And only applies to the test samples identified in the report.

This report shall not be reproduced except in full, without the written approval of Promise, this document may be altered or revised by Promise personnel, and shall be noted in the revision of the document.

Date of Test

Date (s) of Performance of Tests..... : Aug. 23, 2023 ~ Aug. 25, 2023
Date of Issue..... : Jun. 18, 2025
Test Result..... : Pass

Prepared By : Yann
(Yann)
Reviewed by : Chopin Xiao
(Chopin Xiao)
Approved by : Kind yang
(Kind yang)

Report Revise Record

Report Version	Revise Time	Issued Date	Valid Version	Notes
V1.0	/	Jun. 12, 2025	Invalid	Original Report number: PRMS2506107-04ER
V2.0	Jun. 18, 2025	Jun. 18, 2025	Valid	According to the original report, the product photos have been modified. These modifications do not affect electromagnetic compatibility, so no further experiments are required.



TABLE OF CONTENTS

1. SUMMARY OF THE TEST RESULTS.....	4
2. GENERAL INFORMATION.....	5
2.1 GENERAL DESCRIPTION OF THE EUT.....	5
2.2 DESCRIPTION OF THE TEST MODES.....	6
2.3 TEST CONFIGURATION DIAGRAM.....	6
2.4 DESCRIPTION OF THE SUPPORT UNITS.....	7
2.5 LABORATORY INFORMATION.....	8
2.6 MEASUREMENT UNCERTAINTY.....	8
2.7 MEASUREMENT INSTRUMENTS LIST.....	9
3.EMC EMISSION TEST.....	10
3.1 CONDUCTED EMISSION MEASUREMENT.....	10
3.2 RADIATED EMISSION MEASUREMENT.....	14
4.PHOTOS OF THETEST SETUP.....	21
5.PHOTOGRAPHS OF THE EUT CONSTRUCTIONAL DETAILS.....	22

1. SUMMARY OF THE TEST RESULTS

Test procedures according to the technical standards:

EMISSION			
Standard	Item	Result	Remarks
FCC Part 15Subpart B ANSI C63.4: 2014	Conducted Emission	PASS	Meet Class B limit
	Radiated Emission	PASS	Meet Class B limit

NOTE:

(1) "N/A" denotes test which is not applicable in this Test Report



2. GENERAL INFORMATION

2.1 GENERAL DESCRIPTION OF THE EUT

Product Name	Pet Water Dispenser
Trade Mark	N/A
Model Name	WF060, WF040, WF050, WF020, WF020TP, WF020WH, WF050TP, WF070, WF080, WF090, WF100, WF110, WF120, WF130, WF140, WF150, WF150, WF160, WF170, WF180, WF190, WF200, WF210, WF220, WF230, WF030, WF240, WF250, WF260, WF270, WF280, WF290, WF300, WF310, WF320, WF330, WF340, WF350, WF360, WF370, WF380, WF390, WF400, WF410, WF420, WF430, WF440, WF450, WF460, WF470, WF480, WF490, WF500, WF510, WF520, WF530, WF540, WF550, WF560, WF570, WF580, WF590, WF600, WF610, WF620, WF630, WF640, WF650, WF660, WF670, WF680, WF690, WF700, WF710, WF720, WF730, WF740, WF750, WF760, WF770, WF780, WF790, WF800
Mode Distinction	Different model names only.
Sampling model	WF060
Test Sample Number	PRMS012250511A01
Product Description	For a more detailed features description, please refer to the manufacturer' s specifications or the User's Manual
Power Rating	DC 5V by Adapter (AC 120V/60Hz)
EUT Highest internal frequency:	<input checked="" type="checkbox"/> Below 108MHz <input type="checkbox"/> Above 108MHz
Hardware Version Number	N/A
Software Version Number	N/A

2.2 DESCRIPTION OF THE TEST MODES

characteristics generation from EUT, the test system was prescanned and was tested on the basis of the consideration of the following EUT operation mode or test configuration mode which possibly have an effect on EMI emission level.

Pretest Mode	Description
Mode 1	Charging
Mode 2	working

For Conducted Test	
Final Test Mode	Description
Mode 1	Charging

For Radiated Test	
Final Test Mode	Description
Mode 1	Charging

Note:

1. For conducted emission test, test mode 1 was the worst case and only this mode was presented in this report.
2. For radiated emission test, test mode 1 was the worst case and only this mode was presented in this report.
3. We have been tested for all available U.S. voltage and frequencies (For 120V, 50/60Hz) for which the device is capable of operation.

2.3 TEST CONFIGURATION DIAGRAM

Mode 1

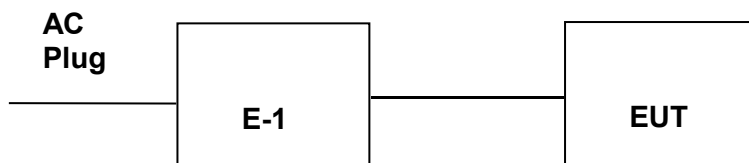

2.4 DESCRIPTION OF THE SUPPORT UNITS

The EUT has been tested as an independent unit together with other necessary accessories or support units. The following support units or accessories were used to form a representative test configuration during the tests.

Accessories equipment

Item	Equipment	Manufacturer	Model No.	Serial No.
N/A	N/A	N/A	N/A	N/A

Auxiliary equipment

Item	Equipment	Manufacturer	Model No.	Serial No.
E-1	Adapter	N/A	N/A	N/A

CableType

Item	Signal Cable Type	Shielded Type	Ferrite Core	Length
N/A	N/A	N/A	N/A	N/A

Note:

- (1) The support equipment was authorized by Declaration of Confirmation.
- (2) For detachable type I/O cable should be specified the length in cm in 『Length』 column.
- (3) “YES” is means “shielded” “with core”; “NO” is means “unshielded” “without core”.
- (4) PC is the FCC DOC is approved.

2.5 LABORATORY INFORMATION

Company Name:	Shenzhen Promise Test Technology Co., Ltd.
Address:	103, Building 1, Yibaolai Industrial City, Qiaotou Community, Fuhai Street, Bao'an District, Shenzhen, Guangdong, China
Telephone:	0755-23319501

2.6 MEASUREMENT UNCERTAINTY

The reported uncertainty of measurement $y \pm U$, where expanded uncertainty U is based on a standard uncertainty multiplied by a coverage factor of $k=2$, providing a level of confidence of approximately 95 %.

A. Conducted Measurement:

Test Site	Method	MeasurementFrequencyRange	U · (dB)	NOTE
Conducted Emission	CISPR 16-4-2	9KHz ~ 30MHz	2.90	

B. Radiated Measurement:

Test Site	Method	MeasurementFrequencyRange	U · (dB)	NOTE
Radiated Emission	CISPR 16-4-2	30MHz ~ 1000MHz	5.19	

2.7 MEASUREMENT INSTRUMENTS LIST

Conducted Emission Test					
Equipment	Manufacturer	Model#	Serial#	Last Cal.	Next Cal.
843 Shielded Room	ChengYu	843 Room	843	May. 13, 2025	May. 12, 2029
EMI Receiver	R&S	ESCI3	100306	May. 14, 2025	May. 13, 2026
LISN	ETS-LINDGREN	3810/2	00045732	May. 14, 2025	May. 13, 2026
Attenuator	SUHNER	ESH3-Z2	100243	May. 14, 2025	May. 13, 2026
843 Cable 1#	FUJIKURA	843C1#	001	May. 14, 2025	May. 13, 2026
Test software	FALA	EZ-EMC	EMC-CON3A1.1		--

Radiation Emission Test					
Equipment	Manufacturer	Model#	Serial#	Last Cal.	Next Cal.
966 chamber	ChengYu	966 Room	966	May. 13, 2025	May. 12, 2029
Spectrum Analyzer	Agilent	N9020A	MY54440442	May. 14, 2025	May. 13, 2026
Low-Noise Amplifier	HEWLETT PACKARD	8447D	2727A05439	May. 14, 2025	May. 13, 2026
Low-Noise Amplifier	RegalWay	RW-LAN-0118-45	202209060001	May. 11, 2024	May. 13, 2026
Log-periodic Antenna	SunAR	JB6	A121411	May. 11, 2023	May. 13, 2026
Horn Antenna	SCHWARZBECK	BBHA9120D	02745	May. 11, 2023	May. 13, 2026
EMI Receiver	R&S	ESCI3	100306	May. 11, 2024	May. 13, 2026
966 Cable 1#	CHENGYU	966	003	May. 11, 2024	May. 13, 2026
Test software	FALA	EZ-EMC	FA-03A2 RE+		--

3.EMC EMISSION TEST

3.1 CONDUCTED EMISSION MEASUREMENT

3.1.1 POWER LINE CONDUCTED EMISSION Limits

FREQUENCY (MHz)	Conducted Emission Limits (dBuV)			
	Class A		Class B	
	Quasi-peak	Average	Quasi-peak	Average
0.15 -0.5	79.00	66.00	66 - 56 *	56 - 46 *
0.50 -5.0	73.00	60.00	56.00	46.00
5.0 -30.0	73.00	60.00	60.00	50.00

Note:

- (1) The tighter limit applies at the band edges.
- (2) The limit of " * " marked band means the limitation decreases linearly with the logarithm of the frequency in the range.

The following table is the setting of the receiver

Receiver Parameters	Setting
Attenuation	10 dB
Start Frequency	0.15 MHz
Stop Frequency	30 MHz
IF Bandwidth	9 kHz

3.1.2 TEST PROCEDURE

- a. The EUT was placed 0.4 meters from the conducting wall of the shielded room with EUT being connected to the power mains through a line impedance stabilization network (LISN). Other support units were connected to the power mains through another LISN. The two LISNs provide 50 Ohm/ 50uH of coupling impedance for the measuring instrument.
- b. Interconnecting cables that hang closer than 40 cm to the ground plane shall be folded back and forth in the center forming a bundle 30 to 40 cm long.
- c. I/O cables that are not connected to a peripheral shall be bundled in the center. The end of the cable may be terminated, if required, using the correct terminating impedance. The overall length shall not exceed 1 m.
- d. For the actual test configuration, please refer to the related Item –EUT Test Photos.

3.1.3 DEVIATION FROM TEST STANDARD

No deviation

3.1.4 TEST SETUP

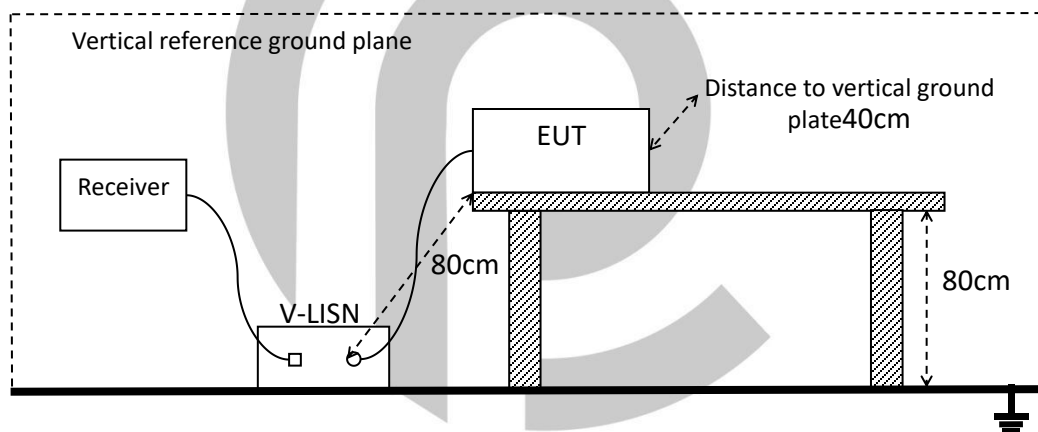

3.1.5 EUT OPERATING CONDITIONS

The EUT was configured for testing in a typical fashion (as a customer would normally use it). The EUT has been programmed to continuously transmit during test. This operating condition was tested and used to collect the included data.

3.1.6 TEST RESULTS

Both charging and operating modes have been tested, and through testing, only the worst operating modes are shown here.

Temperature:	26°C	Relative Humidity:	54%
Phase:	L	Test Mode:	Mode 1
Test Voltage:	AC 120V/60Hz	Test Date:	2023.08.23

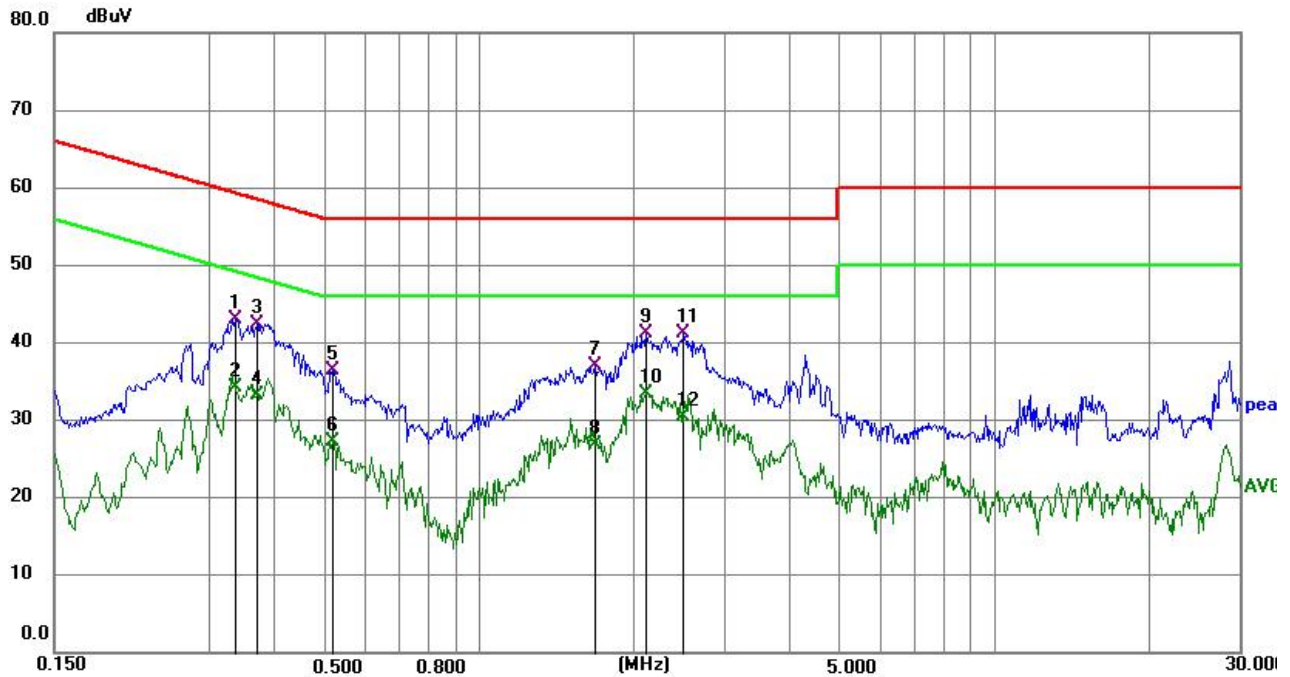

No.	Frequency (MHz)	Reading (dBuV)	Factor (dB)	Level (dBuV)	Limit (dBuV)	Margin (dB)	Detector
1	0.3371	33.17	9.90	43.07	59.27	-16.20	QP
2	0.3371	24.30	9.90	34.20	49.27	-15.07	AVG
3	0.3709	32.57	9.90	42.47	58.48	-16.01	QP
4	0.3709	23.38	9.90	33.28	48.48	-15.20	AVG
5	0.5209	26.53	9.88	36.41	56.00	-19.59	QP
6	0.5209	17.30	9.88	27.18	46.00	-18.82	AVG
7	1.6800	27.10	9.90	37.00	56.00	-19.00	QP
8	1.6800	17.01	9.90	26.91	46.00	-19.09	AVG
9	2.1101	31.29	9.91	41.20	56.00	-14.80	QP
10	2.1101	23.47	9.91	33.38	46.00	-12.62	AVG
11	2.5000	31.26	9.91	41.17	56.00	-14.83	QP
12	2.5000	20.45	9.91	30.36	46.00	-15.64	AVG

Remark:

1. All readings are Quasi-Peak and Average values
2. Margin = Level (Level=Reading + Factor)–Limit
3. Factor = Insertion loss + Cable loss

Temperature:	26°C	Relative Humidity:	54%
Phase:	N	Test Mode:	Mode 1
Test Voltage:	AC 120V/60Hz	Test Date:	2023.08.23

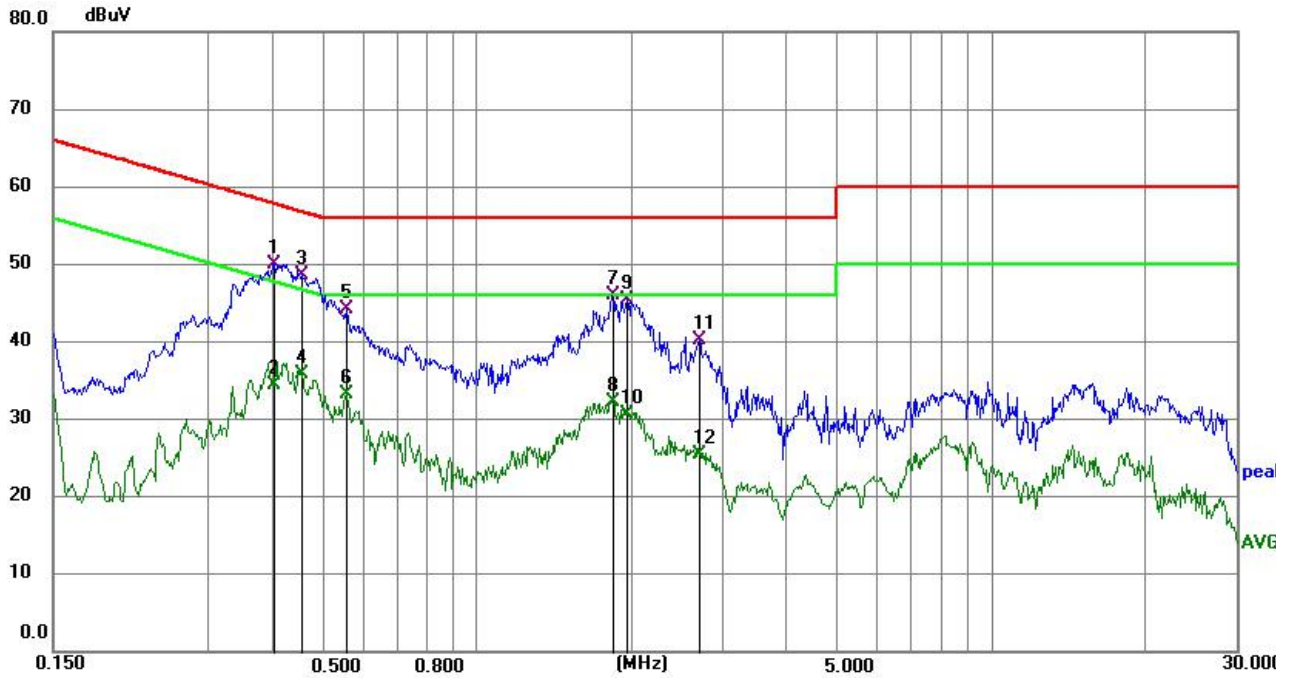

No.	Frequency (MHz)	Reading (dBuV)	Factor (dB)	Level (dBuV)	Limit (dBuV)	Margin (dB)	Detector
1	0.4020	40.09	9.88	49.97	57.81	-7.84	QP
2	0.4020	24.63	9.88	34.51	47.81	-13.30	AVG
3	0.4560	38.71	9.88	48.59	56.77	-8.18	QP
4	0.4560	26.03	9.88	35.91	46.77	-10.86	AVG
5	0.5594	34.36	9.88	44.24	56.00	-11.76	QP
6	0.5594	23.26	9.88	33.14	46.00	-12.86	AVG
7	1.8369	36.13	9.91	46.04	56.00	-9.96	QP
8	1.8369	22.37	9.91	32.28	46.00	-13.72	AVG
9	1.9634	35.55	9.91	45.46	56.00	-10.54	QP
10	1.9634	20.67	9.91	30.58	46.00	-15.42	AVG
11	2.7105	30.36	9.92	40.28	56.00	-15.72	QP
12	2.7105	15.61	9.92	25.53	46.00	-20.47	AVG

Remark:

1. All readings are Quasi-Peak and Average values
2. Margin = Level (Level=Reading + Factor)–Limit
3. Factor = Insertion loss + Cable loss

3.2 RADIATED EMISSION MEASUREMENT

3.2.1 Radiated Emission Limits

Class A: ITE that meets the conditions for Class A operation defined in Section 2.2 shall comply with the Class A radiated limits set out in Table 4 determined at a distance of 3metres.

Class A Radiated Limits Below 1 GHz:

Frequencies (MHz)	Class A (dB μ V/m)
	Quasi-peak
30~88	49.5
88~216	53.9
216~960	56.9
960~1000	60

Class B: ITE that does not meet the conditions for Class A operation shall comply with the Class B radiated limits set out in Table 5 determined at a distance of 3 metres.

Class B Radiated Limits Below 1 GHz:

Frequencies (MHz)	Class B (dB μ V/m)
	Quasi-peak
30~88	40
88~216	43.5
216~960	46
960~1000	54

In case the emission 109(a) limit in the table below has to be followed.

Frequencies (MHz)	Field Strength (micorvolts/meter)	Measurement Distance (meters)
30~88	100	3
88~216	150	3
216~960	200	3
Above 960	500	3

LIMITS OF RADIATED EMISSION MEASUREMENT

FREQUENCY (MHz)	Class A (dBuV/m) (at 3M)		Class B (dBuV/m) (at 3M)	
	PEAK	AVERAGE	PEAK	AVERAGE
Above 1000	80	60	74	54

Note:

- (1) The limit for radiated test was performed in the following:FCC PART 15B.
- (2) The tighter limit applies at the band edges.
- (3) Emission level (dBuV/m)=20log Emission level (uV/m).

FREQUENCY RANGE OF THE RADIATED MEASUREMENT (For unintentional radiators)

Highest frequency generated or Upper frequency of measurement used in the device or on which the device operates or tunes (MHz)	Range (MHz)
Below 1.705	30
1.705 – 108	1000
108 – 500	2000
500 – 1000	5000
Above 1000	5th harmonic of the highest frequency or 40 GHz, whichever is lower

Spectrum Parameter	Setting
Attenuation	Auto
Detector	Peak
Start Frequency	1000 MHz(Peak/AV)
Stop Frequency	5th harmonic (Peak/AV)
RB / VB (emission in restricted band)	30MHz to 1000MHz:100 KHz / 300 KHz Above 1000MHz: 1 MHz / 3 MHz

Receiver Parameter	Setting
Attenuation	Auto
Start ~ Stop Frequency	30MHz to 1000MHz: 100 KHz / 300 KHz Above 1000MHz: 1 MHz / 3 MHz

3.2.2 TEST PROCEDURE

- a. The EUT was placed on the top of a rotating table 0.8 meters above the ground at a 3 meter semi-anechoic chamber room. The table was rotated 360 degrees to determine the position of the highest radiation.
- b. EUT as the center to the edge of the auxiliary device, the distance from the maximum edge to the center of the antenna is 3 meters.
- c. The height of antenna is varied from 1 meter to 4 meters above the ground to determine the maximum value of the field strength. Both horizontal and vertical polarizations of the antenna are set to make the measurement.
- d. For each suspected emission, the EUT was arranged to its worst case and then the antenna was tuned to heights from 1 meter to 4 meters and the rotatable table was turned from 0 degrees to 360 degrees to find the maximum reading.
- e. The test-receiver system was set to quasi-peak detect function and specified bandwidth with maximum hold mode when the test frequency is below 1GHz.
- f. For the actual test configuration, please refer to the related Item –EUT Test Photos.

Note: Both horizontal and vertical antenna polarities were tested and performed pretest to three orthogonal axis. The worst case emissions were reported

3.2.3 DEVIATION FROM TEST STANDARD

No deviation



3.2.4 TESTSETUP

(A) Radiated Emission Test-Up Frequency Below 1 GHz

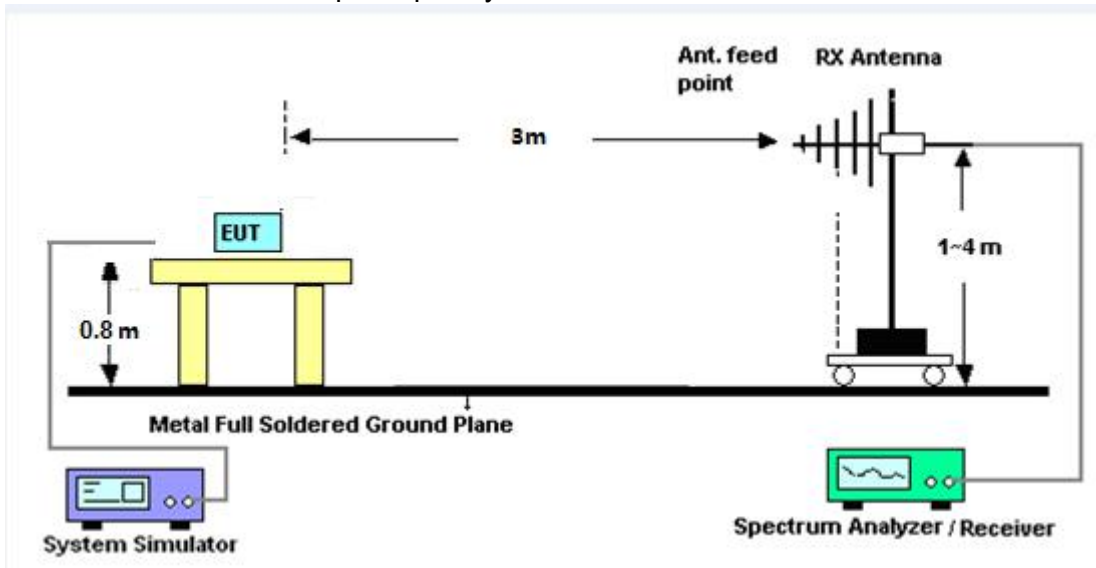

(B) Radiated Emission Test-Up Frequency Above 1GHz

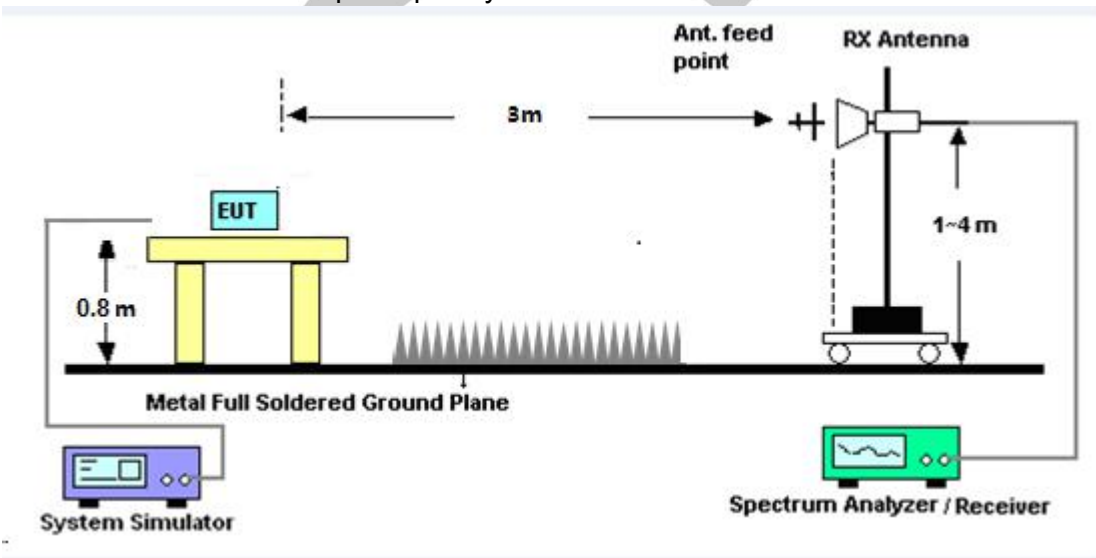

3.2.5 EUT OPERATING CONDITIONS

The EUT tested system was configured as the statements of 2.4 Unless otherwise a special operating condition is specified in the following during the testing.

3.2.6 TEST RESULTS

30MHz -1000MHz

Temperature:	26°C	Relative Humidity:	50%
Phase:	Horizontal	Test Mode:	Mode 1
Test Voltage:	AC 120V/60Hz	Test Date:	2023.08.23

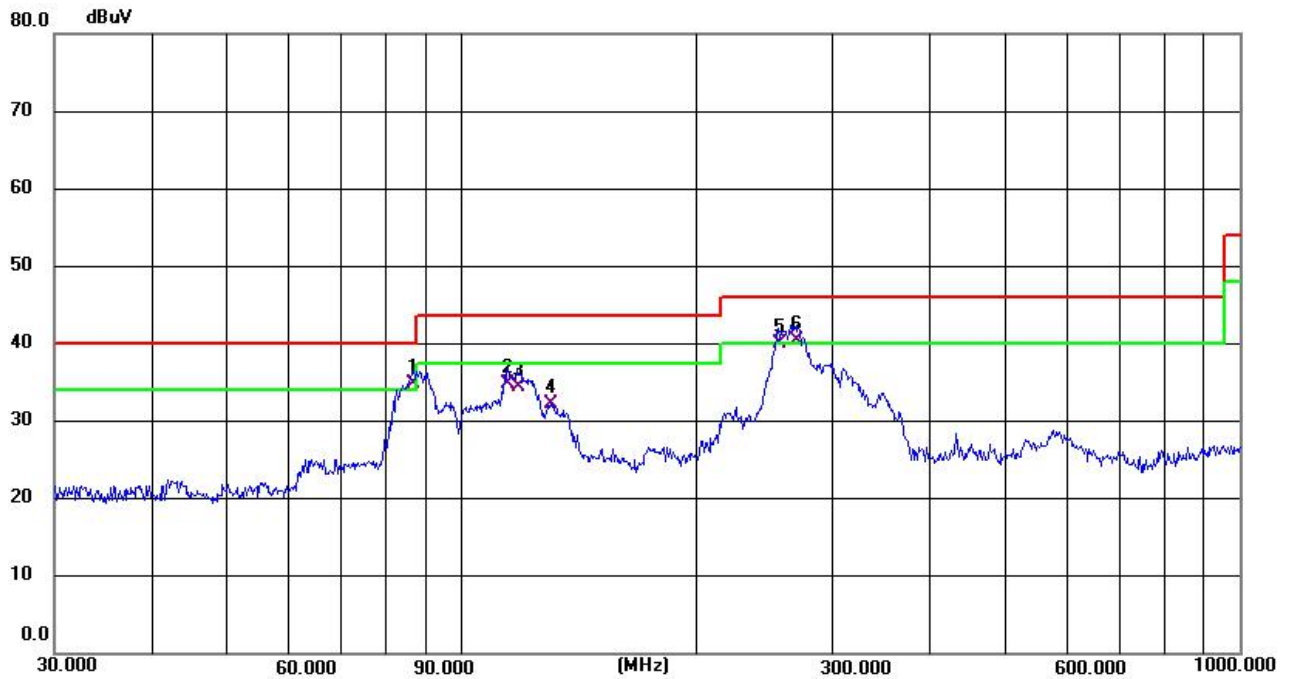

No.	Frequency (MHz)	Reading (dBuV)	Factor (dB)	Level (dBuV/m)	Limit (dBuV/m)	Margin (dB)	Detector
1	86.8067	53.51	-18.78	34.73	40.00	-5.27	QP
2	114.9167	47.35	-12.59	34.76	43.50	-8.74	QP
3	118.1861	47.08	-12.57	34.51	43.50	-8.99	QP
4	130.3788	44.84	-12.59	32.25	43.50	-11.25	QP
5	255.6230	53.23	-13.28	39.95	46.00	-6.05	QP
6	269.4282	51.80	-11.42	40.38	46.00	-5.62	QP

Remark:

1. All readings are Quasi-Peak
2. Margin = Level (Level=Reading + Factor)–Limit
3. Factor= Cable Loss +Antenna Factor–Amplifier Gain

Temperature:	26°C	Relative Humidity:	50%
Phase:	Vertical	Test Mode:	Mode 1
Test Voltage:	AC 120V/60Hz	Test Date:	2023.08.23



No.	Frequency (MHz)	Reading (dBuV)	Factor (dB)	Level (dBuV/m)	Limit (dBuV/m)	Margin (dB)	Detector
1	39.9941	42.53	-9.14	33.39	40.00	-6.61	QP
2	56.0007	54.69	-18.58	36.11	40.00	-3.89	QP
3	90.5374	53.37	-18.75	34.62	43.50	-8.88	QP
4	96.4360	52.83	-17.43	35.40	43.50	-8.10	QP
5	99.8777	51.43	-16.04	35.39	43.50	-8.11	QP
6	202.8103	45.92	-13.07	32.85	43.50	-10.65	QP

Remark:

1. All readings are Quasi-Peak
2. Margin = Level (Level=Reading + Factor)–Limit
3. Factor= Cable Loss +Antenna Factor–Amplifier Gain

SAMPLE OF THE LABEL



Trade Name

Model Number

This device complies with part 15 of the FCC Rules. Operation is subject to the following two conditions:
(1) This device may not cause harmful interference, and (2) this device must accept any interference received, including interference that may cause undesired operation.



4.PHOTOS OF THE TEST SETUP

Radiated Measurement Photo

30MHz- 1GHz

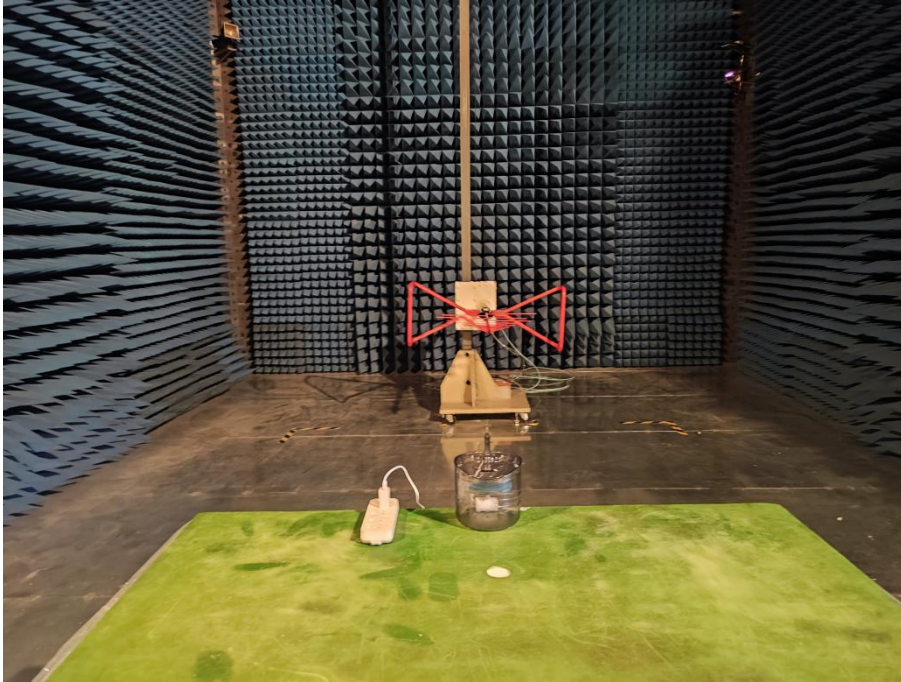

Conducted Measurement Photo



5.PHOTOGRAPHS OF THE EUT CONSTRUCTIONAL DETAILS

Photo 1



Photo 2



Photo 3



Photo 4



*****END OF THE REPORT*****